

REPORT

Biogas from manure and waste products - Swedish case studies



Foreword

The consumption of fossil fuels must be reduced if we are to meet environmental and climate-related goals and reduce the greenhouse effect. In contrast to fossil fuels, biogas is renewable and carbon dioxide neutral. Biogas is also the cleanest fuel on the market and has the potential to replace much of the fossil fuel used in Sweden. The residue produced after anaerobic digestion is a valuable fertilizer and soil conditioner. Organic wastes are recycled through the biogas process to become a resource. This creates a sustainable recycling of nutrients and energy between urban and rural areas, and between consumption and production.

Sweden has made great progress in the exploitation of biogas and is leading the way in purifying biogas for use as a vehicle fuel. The development of new biogas plants has been supported by central Government funding for many years, for example, through local climate investment programs (LIP, KLIMP). New plants and new technologies are continuously being developed. However, in several regions, the demand for biogas is still greater than the supply. This handbook is intended as a source of information on biogas, targeting politicians and decision- and policy-makers in local authorities, farmers and farmers' organisations, and indeed anyone with an interest in biogas in Sweden and abroad.

The handbook starts with a complete description of the biogas process, from the use of substrates to the final distribution of biogas and organic residues. General information is given on biogas technologies, the benefits to the environment and to society, and the economics of biogas. Twelve Swedish biogas plants are then described, which have been particularly successful, and which can therefore serve as models for the future. The plants are grouped into four different categories: co-digestion plants, farm-based biogas plants, sewage treatment plants and industrial plants. Each case study is described as of March 2008. Production figures are given for 2007, unless otherwise stated. Most of the biogas plants described have received financial support via LIP and KLIMP. This support has been vital for the development of many of these plants. The handbook concludes with tips on literature and a list of contact persons, organisations and companies, which may be of use for those planning to start their own biogas plant.

We would like to thank all the biogas plants involved for providing information and illustrations for the case studies. The Swedish Environmental Protection Agency provided financial support for the production of this handbook and Swentec (Swedish Environmental Technology Council) financed the English translation to help international dissemination. Ulf E. Andersson (Swedish Environmental Protection Agency) and Catarina Hedar (Swentec) also took part in the work of the reference group. This handbook is published by the Swedish Gas Centre, the Swedish Gas Association and the Swedish Biogas Association and these associations take full responsibility for the contents.

We hope that this handbook will provide both interesting and informative reading.
Stockholm, 19th May 2008

Jörgen Held Swedish, Gas Centre
Anders Mathiasson, Swedish Gas Association
Anders Nylander, Swedish Biogas Association

Table of contents

Biogas for energy and the environment	4
Political targets related to climate change.....	4
Environmental targets for waste treatment	5
Biogas in Sweden.....	5
History.....	5
Biogas plants.....	6
State funding.....	6
Current production and future potential	6
Benefits.....	7
A strategic energy and fuel resource.....	7
Sustainable waste management.....	7
Energy efficiency.....	7
A thriving countryside	8
Clean fuel for industry.....	8
Regional development and employment opportunities	9
Export potential	9
Environmental benefits.....	9
A renewable source of energy	9
Environmentally-friendly fuel	10
A valuable fertilizer	10
Reduced methane emissions	11
Diverse cultivation.....	11
Improved soil structure.....	11
Problems and challenges	12
Methane leakage.....	12
Odours	12
Competition for agricultural land.....	12
Contaminants in digested sludge.....	13
Too few biogas vehicles and filling stations	13
Biogas technology	14
Biogas: definitions	14
Digestion gas.....	14
Landfill gas	14
Bio-methane from thermal combustion.....	15
The biogas process	15
Three main steps	15
Loading and retention time	16
Temperature	16
Process design	16
Dry digestion	17
Substrate	17
Pre-treatment	17
Pasteurisation	18
Use and distribution of biogas.....	18
Heat.....	19
Combined heat and power production.....	19
Vehicle fuel.....	19
Upgrading	19
The gas grid.....	20
Mixtures with hydrogen	21
Pipeline infrastructure	21
Digestion residues and bio-manure	21

Sludge from water treatment	22
Bio-manure.....	22
Certified bio-manure.....	22
Spreading bio-manure.....	23
Research and development.....	23
Terminology.....	24
Economic factors	25
Investment costs.....	25
Investment costs for farm-based plants.....	25
Investment costs for co-digestion plants	26
Investment costs for upgrading plants	26
Economic support and incentives	27
Energy taxation.....	27
Electricity certificates.....	27
Economic incentives for biogas vehicle owners	28
Investment support.....	28
Case studies of Swedish biogas plants	29
Co-digestion plants.....	29
Experiences from co-digestion	29
The biogas plant in Boden.....	31
The NSR biogas plant in Helsingborg.....	36
The biogas plants in Kristianstad.....	41
The biogas plant in Linköping	47
The biogas plant in Västerås	52
Sewage treatment plants	58
Experiences from sewage treatment plants	58
The biogas plant in Gothenburg	59
The biogas plants in Stockholm city.....	65
Farm-based biogas plants.....	72
Experiences from farm-based biogas plants	73
The biogas plant at Alviksgården.....	74
The biogas plant in Bjuv.....	78
The biogas plant at Hagavik.....	82
Industrial plants.....	85
Experiences from industrial biogas plants	85
The biogas plant at Domsjö fabriker	86
Norrmejeriers biogas plant in Umeå	90
General conclusions and lessons learned.....	95
The biogas puzzle has many pieces	97
Frequently asked questions.....	101
Lists.....	106
Suppliers / Consultants /Business partners	106
Trade organisations	107
Upgrading plants in Sweden.....	108
Biogas plants in Sweden.....	109
References and suggested reading	115

Biogas for energy and the environment

A sustainable supply of energy for societal needs must be secured in the long-term. At the same time, our consumption of fossil fuels must decrease, partly due to a limited and uncertain future supply and partly because of undesirable effects on the environment. Renewable energy sources must be developed in order to meet environmental and climate-related targets, reduce emissions of greenhouse gases, reduce our dependence on oil and secure future energy supplies. In this context, the biogas process has a prominent role to play. Biogas is formed by the anaerobic (i.e. oxygen-free) digestion of organic material by micro-organisms, especially bacteria.

One of the most important tasks we are faced with today is to reduce our exploitation of the earth's finite resources and to develop systems for re-cycling nutrients and energy that are sustainable in the long-term. The majority of food waste, which is currently burnt, should instead be sorted and treated biologically. The Swedish government has defined 16 national environmental goals. Biogas can make a positive contribution to meeting many of these targets including, for example, 'Only natural acidification', 'Limited climate change', 'No eutrophication', and 'High-quality urban environments'. (SGC report 2006, Energy gases and environmental targets)

In contrast to fossil fuels, biogas is renewable and carbon dioxide neutral. Its main constituent, methane, is rich in energy. Biogas has many uses, including the generation of electricity and production of heat. After purification (so-called upgrading), biogas can also be used as a vehicle fuel, thereby constituting a high-quality environmentally-friendly alternative to petrol and diesel. Biogas is also in demand from industry, both as a clean fuel and as a raw material in different manufacturing processes.

Political targets related to climate change

According to EU commission proposals on energy and climate, emissions of greenhouse gases should decrease by 20% in 2020 compared with 1990. This is equivalent to a reduction of 14% compared with the figures from 2005. During the same period, the proportion of energy generated from renewable resources should increase from 8.5% to 20%. These targets will be met partly through a system for trading in emissions rights and partly by measures adopted in other sectors. The trading system will be expanded to include more sectors of the economy, while the number of emissions rights will gradually be reduced, so that emissions covered by the system will decrease by 21% compared with 2005.

A target has also been set in the EU fuel directive, which states that bio-fuels should represent at least 10% of all vehicle fuel consumed in the EU by 2020. This

proportion is currently (in 2008) c. 2%. To reach the target, the EU commission has proposed individual and obligatory targets for the various EU member states. The commission has also adopted new guidelines concerning state funding for environmental protection to help EU member states develop sustainable climate and energy policies.

The targets set by the EU commission imply an increase in the proportion of renewable energy in Sweden from 40% in 1990 (44% in 2008) to 49% in 2020. In 2050, total emissions in Sweden should be less than 4.5 tons of carbon dioxide equivalents per capita and year, and should decrease thereafter. A national target has been set for the period 2008-2012, which states that greenhouse gas emissions should be 4% less in 2012 than they were in 1990.

Furthermore, within the framework of a billion-Crown program for climate and energy investments, the Government has allocated 150 million Crowns to pilot and demonstration projects for second-generation bio-fuels (e.g. new methods of producing bio-fuels from forest primary products).

Environmental targets for waste treatment

The deposition of organic waste in landfills was banned in Sweden in 2005. The Government has also set a target that at least 35% of food wastes from households, restaurants and shops should be recycled through biological treatment by 2010. In 2007, c. 18% of food wastes was treated biologically in various compost and biogas plants. Another target states that by 2015, at least 60% of the phosphorous in sewage should be recycled to productive land, with at least half being returned to arable land. Application of the nutrient-rich residue from the biogas process on agricultural land should help to meet these targets.

Biogas in Sweden

History

The biogas process has long been used in Swedish sewage treatment plants to stabilize and reduce the quantity of sludge. The energy crisis in the 1970's stimulated an increased interest in the production of renewable methane gas from other sources of organic material, such as manure and industrial wastewater from sugar and pulp and paper factories etc. Many plants were built during the 1980's to extract biogas from landfills, and since the mid-1990's, several new plants have been constructed to treat solid wastes from the food industry and food wastes from households and restaurants.

Biogas plants

Sweden has made significant advances in the exploitation of biogas as an energy source. There are 227 biogas plants in the country today (138 sewage treatment plants, 3 industrial, 18 co-digestion plants and 60 landfills, see table). Most of the biogas (c. 60%) is produced at sewage treatment plants, while 30% comes from landfills and 10% from co-digestion plants. There are also eight smaller farm-scale biogas plants, which are mostly designed for electricity generation and heat production.

Successful developments in Sweden during the last ten years have resulted in an increased use of biogas as a vehicle fuel. At present (March 2008), there are 34 upgrading plants in the country. Awareness of the advantages of biogas is increasing, such that the demand for biogas as a vehicle fuel is greater than the supply in some regions, such as the Stockholm area. New technologies for the purification and transport of biogas have been developed and the number of filling stations for biogas in Sweden is continuously increasing.

State funding

Most of these developments have been made possible by state funding, administered by the Swedish Environmental Protection Agency through local investment programs (LIP) and climate investment programs (KLIMP) during the period 1998-2007. Many biogas plants have been built with contributions from LIP and KLIMP and a number of improvements and extensions to existing plants have also been financed in this way. The state investment programs have been an important driving force behind most Swedish biogas projects and in many cases have enabled the development of new technology and demonstration objects (Report 5476, 2005, from the Swedish Environmental Protection Agency).

Current production and future potential

The total annual biogas production in Sweden is almost 1.3 terrawatt hours (figures from 2006). Several studies have concluded that the potential production in Sweden is c. 10 times larger than this, or approximately 14 terawatt hours per year (Linné and Jönsson, 2004). These calculations assume that c.10% of the agricultural land can be used to grow crops for digestion in biogas plants. If the possibility of exploiting cellulose-rich woody materials (to produce so-called bio-methane) is also considered (Held, 2007), the potential production of methane from native raw materials increases to as much as 100 terawatt hours per year. Thus, the production of bio-methane appears to be a realistic means of replacing a significant proportion of the total annual consumption of fossil fuels in Sweden (90 terawatt hours).

Large-scale biogas plants are now being planned, for example outside Malmö and Stockholm. These plants, which will produce more than 50 gigawatt hours per year, will significantly increase the total biogas production in the country. The

economies of scale associated with such large-scale plants will also improve the competitiveness of biogas.

There is today a large unrealized potential to increase the production of biogas from many sewage treatment plants that treat sludge derived from wastewater purification. Many of these plants could produce more biogas if conditions were optimised for the process (Mårtensson, 2007). An increased production of biogas could therefore be realised with little investment and keeping costs to a reasonable level, since these plants already exist.

Benefits

An increased use of biogas as a fuel reduces our dependence on oil, which has important advantages both for the environment and for the security of our energy supply in the long-term. Furthermore, the biogas process plays an important role in the recycling of nutrients between urban and rural areas and in the link between consumption and production.

A strategic energy and fuel resource

Sweden must free itself from its dependence on fossil resources to secure a future supply of energy and fuel for industry and transportation. An increasing demand for crude oil from remote and politically unstable regions is threatening the security of our supply. Interruptions in the supply of fossil fuels threaten to further drive up prices, which would reduce the competitiveness of Swedish industry. The development of biogas represents a strategically important step away from oil dependence which will contribute to a sustainable energy supply in the long-term.

Sustainable waste management

Sustainable and efficient management of organic wastes implies that the nutrients these wastes contain (e.g. nitrogen, phosphorous and potassium) should be recycled to productive land. From this point of view, organic wastes are an important resource that can be exploited in a sustainable way. This also contributes to an increased environmental awareness among those who source-sort their food waste. Utilizing organic wastes in this way also reduces the amount that must be taken care of in some other way, for example by combustion. With the help of the biogas process, the production and consumption of food and energy from all sectors of society can be included in a balanced re-circulation system. Integrated solutions for water, energy and waste management will play an important role in the development of sustainable urban areas.

Energy efficiency

One important factor to consider when arable land is used for the production of bio-energy is the amount of energy obtained after subtracting the energy expended in

its production (i.e. the net energy production). The energy efficiency of growing wheat for bio-fuel production was investigated in a study carried out at Lund Technical University (Börjesson, 2004). The results showed that growing wheat on arable land to produce biogas is c. 3 times more efficient than growing wheat for ethanol production.

Energy can also be produced efficiently by combining ethanol and biogas production. One example of this is the so-called Green gas plant at Norrköping, which is run collaboratively by Agroetanol and Swedish Biogas. In this example, ethanol is produced from wheat, while the residue by-product is used to produce biogas by anaerobic digestion.

A thriving countryside

One of the advantages of biogas technology is that it can be established locally without the need for long-distance transportation or import of raw materials. Small or medium-sized companies and local authorities can establish biogas plants anywhere (i.e. they need not be sited in any particular location, for example, in or close to large cities).

Odour problems can be significantly reduced if manure is anaerobically digested before being spread on the land. This can be a decisive factor in the survival of an agricultural enterprise as an animal producer, especially if the land adjoins built-up areas.

Cultivating crops for bio-energy on arable land is one way of maintaining land within the agricultural sector. Surplus land (e.g. land that is today in 'set-aside') otherwise runs the risk of eventually becoming overgrown. Biogas production based on the cultivation of various agricultural crops thus maintains the potential of the land to grow food crops in the future.

The profitability of agricultural enterprises can improve through the sale of electricity and upgraded biogas, which means that more can survive to prevent the re-forestation of the agricultural landscape. In turn, this will result in more job opportunities and a thriving rural economy.

Clean fuel for industry

Methane is a fuel in demand by industry, partly because it is a gas, which gives a high-quality combustion that can be precisely controlled. Methane burns with a clean and pure flame, which means that boilers and other equipment are not clogged by soot and cinders. This leads to a cleaner workplace environment and less wear and tear on the plant. The methane molecule can also be used as a raw material in many different manufacturing processes, with diverse final products such as paints, plastics, furniture, animal feeds and lubricant oils.

Regional development and employment opportunities

The involvement of many interested parties in planning, construction, cost estimation, administration and distribution is needed to ensure the successful development of biogas as a vehicle fuel. In turn, this creates new job opportunities, both locally and regionally. There are already several regional collaborative efforts focused on biogas (Biogas West, Biogas South) and several more are planned (Biogas East, Biogas North, Biogas Central). Promoting biogas also implies an investment in job creation and regional development.

Export potential

There is a great deal of international interest in biogas technology. Strong support to develop the domestic market in Sweden would help biogas companies expand to become successful in the much larger export markets. Sweden enjoys a leading position in the world today with respect to biogas technology and upgrading and gasification technologies. There are 34 upgrading plants in Sweden today (March 2008), which is the largest number of any country in the world (source: SGC). Given a continued national effort to develop biogas, Swedish companies can grow and export advanced Swedish biogas technology and know-how on the international market. This will lead to the creation of even more job opportunities in Sweden.

All this implies a great deal of activity in the field of biogas in the coming few years. The development of biogas will not only benefit the environment and improve the security of our energy supply, but it also means a push in the right direction for the economy in general, for individual companies, and for regional development.

Environmental benefits

The biogas process has many advantages from the point of view of the environment, especially since it results in two environmentally-friendly final products, biogas and an organic residue, which is sometimes called bio-manure. Biogas is the most environmentally-friendly vehicle fuel on the market today, and can also be used to generate electricity, produce heat and as a raw material in industry. Upgraded biogas can replace natural gas, since it can be used in the same way. Bio-manure is a valuable fertilizer, which when returned to soil, results in a recycling of nutrients between urban and rural areas.

A renewable source of energy

Biogas is a renewable source of energy. The carbon dioxide that is released when biogas is combusted and mixed with the oxygen in the air does not contribute to the greenhouse effect, since the carbon in the biogas is already in the biosphere circulation above the earth's crust. The same amount of carbon dioxide would be released if the biological material was allowed to decompose instead. The carbon in

the methane molecule produced by the biogas process originates from the carbon dioxide in the air that the plants have taken up by photosynthesis. Natural gas was also produced in this way, but the carbon in natural gas has been stored in the earth's crust during millions of years and is therefore not carbon dioxide neutral when it is extracted from these fossil layers within the earth. Thus, compared with natural gas, biogas has significant benefits for the environment.

Environmentally-friendly fuel

Biogas has many advantages as a replacement for petrol and diesel. Biogas gives the smallest emissions of carbon dioxide and particulate matter of all vehicle fuels on the market today. The methane molecule is the simplest of all hydrocarbons, which means that the exhaust produced by combustion is very clean. Emissions of carbon monoxide, hydrocarbons, sulphur compounds, nitrogen oxides, heavy metals and particulate matter are negligible. A gas engine is quieter than a diesel engine, which means a better workplace environment for professional drivers. Methane is a safer fuel than petrol or diesel, since the gas is not poisonous and is lighter than air. If a leak should occur, methane would quickly rise through the surrounding air and become diluted.

Calculations show that replacing fossil vehicle fuels by biogas reduces the carbon dioxide emission per unit of energy by 90%. The benefits can be doubled if biogas is produced from manure, since this decreases emissions of both methane and carbon dioxide. The reduction, measured in carbon dioxide equivalents, can then be as large as 180% per unit of energy.

A valuable fertilizer

All the nutrients in the original substrate (e.g. nitrogen, phosphorous, potassium, calcium and magnesium) are retained in soluble and plant-available forms in the residue, and cannot be lost by leaching, since the digestion takes place in closed containers.

One problem with conventional handling of manure is that the nutrients it contains are in relatively unavailable forms and therefore cannot be effectively taken up by plant roots. As a consequence, nutrients (especially nitrogen and phosphorous) leach from the soil and reach watercourses and eventually the sea, where they cause eutrophication. However, these nutrients will be in more easily available forms if the manure is anaerobically digested before it is spread on the soil. For example, organically-bound nitrogen in manure and crop residues is converted to ammonium during anaerobic digestion, which is a soluble form of nitrogen that plant roots can easily absorb.

Thus, anaerobic digestion produces an effective and easily handled nitrogen fertilizer which can be incorporated in soil in precise amounts. Nitrogen losses and

environmental impacts due to ammonia and nitrous oxide emissions are also minimized because plants can quickly extract the nutrients from the digested manure. The leaching of water-soluble nitrate is also reduced, which decreases the risk of nitrogen leaching to groundwater and surface waters.

A more effective use of the nutrients in manure reduces the need for mineral fertilizers. This decreases costs for the farmer and also results in energy-savings, since fossil raw materials and energy are needed to manufacture mineral fertilizers.

Digested manure smells much less than fresh manure when it is spread, which enables applications close to built-up areas, without causing any inconvenience. Anaerobic digestion also reduces the number of infectious microorganisms and weed seeds in the material, especially if the digestion process is thermophilic (55°C).

Reduced methane emissions

Methane is a greenhouse gas. In a 100 year period, its contribution to the greenhouse effect is 20 times greater than that of carbon dioxide. One problem with conventional methods of handling and storing manure is that spontaneous emissions of methane can occur. These methane emissions can be avoided by digesting the manure in closed chambers (reactors) where all the methane is collected as biogas for later combustion. It is important in this context that the digested residues are covered, since some methane can still be formed before the bio-manure is incorporated in the soil. Nowadays, the methane produced by many landfills is collected, which further reduces losses to the atmosphere.

Diverse cultivation

Many different crops are suitable for biogas production, including for example ley crops, cereals, maize, and sugar beet. Monocultures are therefore avoided, in contrast to the situation, for example, with ethanol production from only sugar cane or wheat or rape methyl ester (RME) from oilseeds (rape). A more varied and balanced crop rotation can reduce the need for chemical pesticides.

A varied crop rotation that includes legumes such as peas and clover also adds nitrogen to the soil. With the help of soil-living microorganisms, legumes capture nitrogen from the air, incorporating it into plant material. Anaerobic digestion of these harvested crops produces a bio-manure that is rich in nitrogen, which can then be returned to the soil in an easily-available form. This can be especially important in ecological farming, where mineral fertilizers cannot be used.

Improved soil structure

Long-term cereal cultivation without ley crops and grazing animals can lead to decreases in soil organic matter content, poor soil structure and consequent reductions in yield. A lack of manure additions to the soil in such a farming system

can be compensated by digesting a part of the harvested yield in a biogas plant, and re-cycling the nutrients and organic matter in the residue to the land. The establishment of grass leys for biogas production improves soil structure as a result of the well-developed root system and enhanced earthworm activity.

Problems and challenges

As discussed above, biogas and bio-manure benefit both the environment and society in many ways. As such, biogas will surely play a significant role in the future, with respect to energy supply and waste management in Sweden. However, some potential problems and challenges need to be addressed and resolved if biogas production in Sweden is to continue to increase.

Methane leakage

Methane is a greenhouse gas, so that leaks during handling and treatment of biogas should be avoided. A great deal of work is already being carried out at biogas and upgrading plants to avoid and detect leaks. For example, 'Avfall Sverige' ('Swedish Waste Management') has initiated a voluntary scheme whereby biogas producers regularly perform an inventory of emissions. Any leaks that are discovered during the inventory must be dealt with.

Prior to spreading, bio-manure should be stored and transported in closed containers. In this respect, it is important to note that methane losses from bio-manure are much less than when fresh manure is handled.

Odours

Problems caused by odours are sometimes experienced at biogas plants, usually in connection with waste deliveries prior to digestion. New technologies are being developed to address these problems. For example, some plants have installed compost filters that reduce odours during handling and pasteurization of fresh wastes.

Competition for agricultural land

Calculations of the future potential biogas production in Sweden include the digestion of agricultural crops, and not just organic wastes. No direct competition with food production will occur if the land that is today in set-aside (10-15% of the cultivated area) is instead used to grow crops for bio-energy. Thus, growing crops for biogas is an effective way of utilizing the land, maintaining its capacity for future crop production. Marginal land that would otherwise become re-forested can be advantageously exploited for biogas production. Furthermore, arable land is most effectively utilized when the by-products of food production such as tops and other crop residues are used to produce biogas. However, even if there is no real

conflict with food production, competition could arise if land was used to grow crops for alternative means of producing energy (e.g. ethanol).

Contaminants in digested sludge

The digestion residue produced by anaerobic decomposition of the sludge from sewage treatment plants can contain undesirable substances, such as residues of pesticides, medicines and relatively high concentrations of heavy metals. These digestion residues are not at all comparable to the bio-manure produced at plants that digest cleaner organic wastes, such as manure, crops, source-sorted food waste and clean process liquids from the food industry. Bio-manure is uncontaminated, and its quality is ensured by certification (SPCR 120).

Work is ongoing at sewage treatment plants to improve the quality of the digestion residue and therefore extend its uses. In this context, it is important to work 'upstream', that is to detect and eliminate undesirable substances in the wastewater before it reaches the treatment plant. This kind of work has been initiated at a number of sewage treatment plants in Sweden within the project 'Pure nutrients from waste' (Revaq). The objective is to increase the agricultural use of nutrient-rich digestion residues produced at sewage treatment plants.

Too few biogas vehicles and filling stations

Biogas production is not meeting the ever-increasing demand in Sweden. In certain cases, the use of natural gas may therefore be important as a 'back-up' to ensure a steady supply of gas, at least in this initial phase until biogas production reaches a sufficient volume.

New filling stations are opening to keep pace with increases in biogas production, but demand for biogas is still larger than supply in many regions. One reason why potential biogas producers hesitate to enter the business may be that the long-term market demand for biogas seems uncertain. There are currently too few biogas vehicles and filling stations, which results in a Catch-22 situation.

Another reason why the potential market in Sweden for biogas has not yet been fully exploited is that it is time-consuming and costly to build a functioning distribution system. New local and/or regional pipe networks must be laid for biogas, since the existing gas grid in Sweden is limited to certain parts of the country, where there is access to natural gas. An alternative is to transport the biogas as a compressed liquid.

Biogas technology

Biogas is formed when organic material is decomposed by microorganisms in an oxygen-free environment. This process of anaerobic digestion occurs naturally in many environments with limited access to oxygen, for example in bogs and marshes, rice paddies and in the stomach of ruminants. This natural process is exploited in a biogas plant, where organic material is placed or pumped into a completely airtight container or digestion chamber (reactor). The final products are biogas and a nutrient-rich organic residue (bio-manure).

Biogas: definitions

Methane constitutes the energy-rich part of biogas. Biogas is composed of 45-85% methane and 15-45% carbon dioxide, depending on the conditions during production. Biogas also includes small amounts of hydrogen sulphide, ammonia and nitrogen. Biogas is often saturated with water vapour. The amount of biogas is usually stated in units of normal cubic metres (N m³), which is defined as the volume of gas at 0 °C and atmospheric pressure.

Methane is also a constituent of natural gas, so that purified biogas can be mixed with natural gas and used in the same way. Natural gas consists of hydrocarbons in gas form, created 50 to 400 million years ago by the anaerobic decomposition of plants, plankton, algae etc. The methane content of natural gas is c. 90% or more. This gas is extracted from fossil layers in the earth's crust, together with oil or in separate gas fields.

Digestion gas

The biogas obtained from sewage sludge, manure, agricultural crops etc. in a digester is sometimes called digestion gas. Digestion gas generally has a relatively high methane content (at least 55%). Digestion gas obtained from co-digestion of different substrates is sometimes distinguished from that extracted solely from sewage sludge. Co-digestion means that many substrates are digested simultaneously in a biogas process, for example source-sorted food wastes or slaughterhouse wastes together with manure and sewage sludge. Compared with the digestion of sludge from sewage treatment plants, co-digestion usually results in a biogas of larger methane content.

Landfill gas

Gas extracted from landfills has the smallest methane content (45-55%), because methane production from the landfill mass is not optimised in the same way as it is in a digester. Some air will also leak into the landfill as the methane is extracted by fans. The landfill gas is usually extracted with the help of perforated pipes (so-called

gas wells) that are drilled or pressed into the landfill. Landfill gas is usually used for heating. Even if the gas is not used, it is usually collected and 'flared off', partly to reduce emissions of greenhouse gases, and partly to prevent explosions. Methane formation in landfills is a slow process which can continue for 50 years or longer in landfills consisting of mixed wastes. Due to the ban introduced on deposition of organic wastes, no new landfills are being constructed to cater for such wastes, but existing landfills will continue to produce methane long into the foreseeable future (30 to 50 years).

Bio-methane from thermal combustion

Bio-methane is a generic name for gas that is mostly composed of methane that can be extracted from biological material. Bio-methane includes, for example, biogas obtained from anaerobic digestion, but it can also be extracted by the combustion of cellulose-rich materials such as woody raw materials and carbon-rich waste products. This so-called thermal combustion is an effective method of producing methane. The final product, which is called substitute natural gas (SNG) or sometimes synthetic natural gas, can be distributed and used in the same way as natural gas and upgraded biogas. SNG is produced by the decomposition of the carbon-rich material by heating. The gas that is produced undergoes several process steps (e.g. purification) before the final synthesis of methane.

In Sweden, projects dealing with the production of bio-methane from thermal combustion are ongoing in Piteå and Värnamo. In Piteå, the combustion plant treats a by-product from a pulp and paper factory. In Värnamo, the plan is to produce hydrogen-rich bio-methane by the pressurized combustion of biomass. More such projects are planned in Sweden, for example in Malmö and Gothenburg. These plants are expected to begin commercial operations in 2012.

The biogas process

In the biogas process, many different microorganisms participate in a complex web of interacting processes which result in the decomposition of complex organic compounds such as carbohydrates, fats and proteins to the final products of methane and carbon dioxide.

Three main steps

The biogas process can be divided into three main steps. In the first step (hydrolysis), microorganisms, aided by enzymes, decompose the complex organic compounds to simpler compounds such as sugar and amino acids. A number of intermediate products are formed in the next step (fermentation), including alcohols, fatty acids and hydrogen gas. Methane is formed in the last step by a unique group of microorganisms (methanogens) that have very specific environmental requirements. They grow slowly and die if they come into contact

with oxygen. They also need access to certain vitamins and trace elements and are sensitive to rapid changes in temperature, acidity (pH) and other environmental factors.

Loading and retention time

The technology of the biogas process must be adapted to the fact that it is a biological process. Often, the process is started slowly, step-by-step, to allow the microorganisms to adapt to new conditions and substrates. The loading, that is the inflow rate of new material, is successively increased up to a maximum value. This can take several months depending on the substrate being digested. The loading is normally expressed as the organic loading rate (OLR), for example, 2 kg organic material per cubic metre (reactor volume) per day. The amount of organic material is sometimes expressed as volatile solids (VS).

The organic material is treated in the reactor for a certain period of time. The average time allowed for digestion of the material in the reactor before it is removed is called the retention time. This varies depending on the properties of the substrate and on how much methane can be extracted. The retention time is sometimes expressed as the hydraulic retention time (HRT), which normally varies between 10 and 40 days. The shortest retention times are usually found at sewage treatment plants, whereas co-digesters often require longer retention times.

Normally, between 0.5 and 1 cubic metre of biogas can be extracted from 1 kg of dry organic material, depending on the substrate. Digesting only manure will produce c. 1 cubic metre of biogas per cubic metre of reactor volume per day, whereas much more can be produced (2 to 3 m³ biogas per m³ per day) if more energy-rich substrates are used, for example different crop residues and food wastes.

Temperature

Temperature is an important factor to consider in anaerobic digestion. Two different temperatures are generally used in biogas processes: 37°C (mesophilic) and 55°C (thermophilic). Mesophilic and thermophilic microorganisms grow best at these temperatures. Heat must be supplied to the biogas process since, in contrast to aerated composts, it is not self-heating. The reactor must also be well insulated. Mixers are installed in the chamber to maintain a constant temperature. Mixing also improves the contact between the substrate and the microorganisms and prevents layering in the material.

Process design

The biogas process can be designed in different ways. The biogas is collected from the top of the container, while the substrate is usually pumped in. The residue is removed by pumping or through an overflow for later storage or recirculation to the process. The one-step digester, which uses a single reactor for the complete

microbiological process, is the simplest and commonest design. All decomposition steps take place simultaneously and in the same place. The two-step digester is another variant, in which the process takes place in two consecutive steps. Hydrolysis and fermentation take place in the first reactor, although some methane is also produced. The residue or leachate from the first chamber is then fed into the second reactor, which is specially adapted for methane production. For example, it can be designed as an anaerobic filter with inbuilt carrier materials to which the methanogens can attach, so that they grow better. This often results in a fast and effective production of biogas with methane contents of up to 85%.

Continuous digesters treating liquid substrates (e.g. municipal and industrial wastewaters) continuously pump new material into the digester, giving a constant inflow of substrate throughout the day. Sludge-like materials such as manure and sewage sludge can also be fed into the reactor more or less continuously, in a process called semi-continuous digestion. Solid materials such as crop residues and food wastes are normally fed to the process less frequently and in larger portions. Adding liquids to these solid materials can enable a more continuous pump feeding of the digester.

Dry digestion

A method known as dry digestion can be applied to dry raw materials. Dry substrates are defined as materials of low water content, and therefore high values of 'dry weight' (i.e. larger than 20-25%). In this design, digestion is completed 'portion by portion', that is the raw material remains in the reactor during the entire process, with neither removal nor addition of substrate. The only moving parts are pumps that are installed outside the reactor for excess water and warm water. The method is therefore robust compared with conventional digesters, in which mixers are usually needed. The amounts of liquid required are also much smaller than in wet digestion, which means that the residue does not need to be de-watered. Dry digesters are being planned in Helsingborg and Mörrum.

Substrate

Many kinds of organic material are suitable as a substrate for anaerobic digestion including, for example, sludge from sewage treatment plants, food wastes from households, restaurants and shops, manure, crop residues and process water from the food industry. Co-digestion with different substrates often increases methane production, in the sense that the amount of methane produced per unit of organic material is larger than when each substrate is digested separately.

Pre-treatment

In certain cases, the substrate must be pre-treated before it can be added to the process. Dry materials may need wetting, while highly liquid substrates, for example wastewater and sludge from sewage treatment plants, must be de-watered

to prevent them from filling up too much of the digester volume. Foreign objects (e.g. plastic, metals) must be removed from source-sorted food wastes originating from households and shops etc. Metal objects can be removed with the help of magnetic separation. If food wastes are collected in plastic bags, these must be emptied and the bags removed by screening.

Organic material is sometimes pre-treated to produce a finer material using mills or cutting screws in order to increase its availability to microorganisms in the process, for example when plant materials with a high fibre content are digested. This type of pre-treatment is also commonly used prior to digestion of food wastes which are often quite heterogeneous. A finer and more homogeneous material gives a shorter treatment time in the reactor and produces more biogas per unit of organic substrate. New technologies are rapidly being developed for this kind of pre-treatment, and new biogas plants that have adopted such technologies to treat sorted food wastes can be found in Jönköping, Malmö, Helsingborg and Skellefteå.

Pasteurisation

Biogas plants treating materials of animal origin (e.g. slaughterhouse waste and manure) must pasteurize these substrates before they can be digested. The regulations are administered by The Swedish Board of Agriculture within the so-called 'Animal By-product Ordinances'. The material is normally pasteurized before it is fed into the digester by heating to 70°C for at least one hour. Digesters treating manure from the farm can be exempted from this regulation if the residues are spread on the same farm. Substrates that are not of animal origin are sometimes also pasteurized. The Swedish Environmental Protection Agency issues general guidelines on pasteurization.

Use and distribution of biogas

The energy in biogas can be exploited in different ways. For example, it can be used for local heating or remote heating (via district heating networks). Biogas can also be used to generate electricity, thus contributing to an increased proportion of 'green electricity' distributed through the grid. New systems for storage and distribution of biogas are being developed now that it is increasingly used as a vehicle fuel. Biogas can be distributed in separate pipes or through the existing gas grid. It can also be transported as compressed gas or in liquid form.

Local consumption of biogas in the vicinity of the plant is still commonest. A pipe is laid from the production plant, most often to a single user. Gas up to pressures of 4 bars can be distributed in pipes constructed of plastic (polyethylene). Upgraded and compressed biogas can be distributed to filling stations in a mobile container system. Compared with gas at atmospheric pressure, the energy per litre is

concentrated 600 times by converting methane to a liquid form (liquefied natural gas, LNG, or liquefied biogas, LBG).

Heat

For heat production, only water vapour needs to be removed from the gas prior to combustion. Boilers are found at most biogas plants, where the gas is often used to heat nearby buildings. Excess heat can be distributed to more distant premises, either directly through gas pipes or indirectly through district heating networks. However, it is quite common in smaller plants that some of the biogas must be 'flared off', especially in the summer when demand is lower.

Combined heat and power production

Biogas can be used to produce both power and heat in the same plant. About 30-40 percent of the energy can be extracted as electricity and the remainder as heat. As in the case when only heat is produced, the gas must be dried before combustion. In addition, particulate matter and, if necessary, any corrosive substances (e.g. hydrogen sulphide) must also be removed. Diesel and gas engines (e.g. the Otto engine) are well suited to small-scale power plants. One kind of diesel engine, the so-called dual-fuel engine, found, for example, at some German biogas plants can be driven on both diesel and gas. Gas turbines can be used at larger plants. Micro-turbines in the range between 25 and 100 kilowatts have been introduced in recent years for the combined production of power and heat from biogas.

Vehicle fuel

The use of biogas as a vehicle fuel is continuously growing, both in Sweden and abroad. Most filling stations to date are found in south and west Sweden, but the number is also increasing in other parts of the country. Both biogas and natural gas are called vehicle gas when they are used as fuel.

Cars that run on vehicle gas are often called bi-fuel cars because they have separate tanks for petrol and gas. The same engine is used for both fuels and the car automatically switches to petrol if the gas runs out. On the other hand, gas-driven heavy vehicles such as buses and trucks are built to run only on gas. The Otto engine is normally used, which means that fuel consumption is somewhat higher than for diesel engines. The dual-fuel engine, which can run on both vehicle gas and diesel, is now being introduced onto the market. Up to 90% of the diesel can be replaced by gas. This engine is an environmentally-friendly alternative that is suitable for heavy vehicles, because of the low fuel consumption and low emissions of nitrogen oxides and particulate matter.

Upgrading

In order to use biogas as vehicle fuel, its energy content must first be increased by removing carbon dioxide, so-called upgrading. Upgraded biogas is 'odourised' with a

scented additive to enable the detection of any gas leaks. Water and contaminants such as hydrogen sulphide and particulate matter must also be removed. Finally, the gas must be compressed under a pressure of c.200 bars before it can be used. Upgraded biogas has a methane content of at least 95% and can therefore be used in the same way as natural gas. The energy content of one normal cubic metre (the volume of gas at 0°C and atmospheric pressure) of upgraded biogas is equivalent to that obtained from 1.1 litres of petrol.

Physical absorption (water wash) is the commonest technique for upgrading biogas. The method is based on the fact that carbon dioxide is more soluble in water than methane. A variant of this method is to use a solvent that absorbs carbon dioxide more efficiently than water. Other methods include absorption with a solution of dimethylether derivative (trade names Genosorb and Seloxol) or absorption by a chemical reaction with a solvent (trade name Coaab). Pressure swing adsorption (PSA), which separates different substances on the basis of their molecular size, is another common technique employed to upgrade biogas.

Carbon dioxide can also be separated from methane using cryogenic technology. This method is based on the fact that the two gases have different boiling points, which means that carbon dioxide can be removed by cooling the biogas to a liquid form. The liquefied carbon dioxide can then be used as a coolant in the food industry or in refrigerated transport.

Membrane technology and in-process methane enrichment are other upgrading technologies which may be introduced in Sweden in the near future. In the membrane methods, biogas is led through thin fibre holes that trap methane but let water and carbon dioxide through. As the name suggests, with in-process methane enrichment, methane is separated from carbon dioxide before the gas leaves the digester. In this method, the contents of the digester are circulated over a desorption column, where air is blown through the sludge to remove dissolved carbon dioxide. The sludge is then returned to the digester, with the result that the biogas that is produced is enriched with methane.

The gas grid

The sale and marketing of biogas is considerably helped by the possibility of connecting biogas production plants to the general gas grid. Temporary peaks in production can then be effectively regulated, for example in the summer when heating requirements are lower and locally produced biogas is often 'flared off'. Before the gases are mixed in the grid, a higher hydrocarbon (usually propane) is added to the upgraded biogas to attain the same energy content as natural gas and thus to ensure a fair debiting of customers.

Biogas can reach new markets through the gas grid. For example, apart from vehicle fuel, biogas is a suitable fuel to run gas ovens and fires, to heat greenhouses and water heaters and it can also be used as a raw material in various manufacturing processes.

Filling stations with access to the general gas grid have an advantage since customers can use natural gas when the supply of biogas runs out. This ensures an even supply of vehicle gas and reduces the transport of gas by road. The Swedish natural gas grid currently stretches from Malmö to Stenungsund. The long-term objective is to increase the amount of biogas added to the grid, which would increase the proportion of renewable or 'green' gas distributed to the consumer. Biogas already accounts for more than 50% of the vehicle gas used today.

Mixtures with hydrogen

Another possibility is to mix natural gas, biogas and hydrogen gas. In the future, hydrogen could be mixed and distributed in an existing infrastructure of pipe networks and benefit from an existing market for gas. Adding small amounts of hydrogen to natural gas can increase the proportion of 'green' gas if the hydrogen is produced from renewable energy sources. A mixture of methane and hydrogen (so-called hythane) has been successfully tested in trials with city buses in Malmö.

Pipeline infrastructure

Projects are now being planned in which several farmers and/or local authorities are together investing in upgrading plants in order to take advantage of economies of scale. The farms will be linked by pipe networks where the raw gas from the biogas plant at the farm is transported to a central upgrading plant and from there to the filling stations. In this way, biogas can be produced locally, close to the source of the raw materials for digestion, while the gas is distributed through pipe networks to the consumer. This is much more cost-effective than systems where crop residues and manure must be transported long distances by truck to biogas plants that have access to upgrading facilities. This kind of collaborative project is being planned on the Bråland plain in Västergötland, as well as outside Varberg.

Digestion residues and bio-manure

In anaerobic digestion, most of the carbon and energy in the original substrate is recovered in gas form as methane and carbon dioxide. This means that the volume of the solid material decreases during digestion. Indeed, anaerobic digestion has long been employed as a method to reduce sludge volumes at sewage works. However, the organic material is rarely completely decomposed during the process. A digestion residue is formed, which apart from water and organic material, also contains microorganisms and various nutrients.

This nutrient-rich final product can be used as fertilizer. The residue is also a good soil conditioner as it adds organic matter to the soil. The digested material removed from the reactor is usually covered during storage, for example with straw or a gas-tight membrane, to prevent losses of methane, nitrous oxide and ammonia. The residue is sometimes composted. One example of this can be seen at the biogas plant in Borås, where there are only limited possibilities to spread residues in the immediate vicinity of the plant. The residue is instead composted to produce a soil conditioner.

The residue cannot contain contaminants (e.g. heavy metals, infectious microorganisms or residues of medicines or pesticides etc.) if it is to be used as fertilizer. Visible contaminants such as plastic and glass objects are also unacceptable. In general, we can say that a contaminated raw material will give a contaminated final product. Careful source-sorting is therefore critical for a successful outcome. Digestion residues can be classified and named according to their origin (i.e. the substrate used).

Sludge from water treatment

Digested sewage sludge originating from water treatment plants usually has a high water content, so that de-watering is required before spreading. The sludge often has a high phosphorous content, which is valuable from the point of view of plant nutrition. However, the content of heavy metals can limit its use in agriculture. After mixing with structural materials such as sawdust and sand, the digested sludge is typically used as a filler material in the construction of roads, golf courses etc. or as a cover material in landfills.

Bio-manure

The residue produced at biogas plants that digest relatively uncontaminated organic wastes such as manure, source-sorted food wastes, crop residues, process water from the food industry etc. is usually termed bio-manure. It has a similar consistency to liquid cattle or pig manure and is rich in nutrients. There are usually no problems with contamination and the bio-manure is therefore well suited for use as a fertilizer in agriculture.

Certified bio-manure

A certification system in Sweden enables owners of biogas plants to quality-control their bio-manure and get it approved as certified bio-manure. The certification of bio-manure, which is voluntary, is governed by regulations (SPCR 120) compiled by the SP Technical Research Institute of Sweden in collaboration with 'Avfall Sverige' ('Swedish Waste Management'). The certification system makes the entire chain of production from raw material to final product transparent, and contents of contaminants such as heavy metals and infectious bacteria are also regularly checked.

Animal by-products such as slaughterhouse wastes must be pre-treated by heating at 70°C before they are digested. Amongst other requirements, no Salmonella bacteria should be detected in bio-manure. A 'safety-first' attitude is encouraged, as is staff participation in training courses which provide access to up-to-date information. Sewage sludge cannot be used as a substrate in biogas plants that produce certified bio-manure, as the content of heavy metals in the final product can be too large. Certification improves the market for bio-manure, as it increases the confidence of consumers in the product.

Spreading bio-manure

Bio-manure is usually spread using the same methods as untreated liquid manure (i.e. a tractor equipped with manure container and spreader). Another method is being employed in Helsingborg, in which bio-manure is pumped out to farms in buried pipelines. This avoids the need to transport the bio-manure to the fields by truck, thus saving energy. It also ensures that the bio-manure does not come into contact with substrates that have not yet been pasteurized. This can otherwise be a risk if the same trucks are used to transport both the raw substrate and the final bio-manure to and from the plant.

A pipeline system also opens up possibilities to introduce new application technologies on those soils which cannot withstand the heavy application equipment that is normally employed. For example, the bio-manure can be pumped directly from a storage tank to the tractor's sprayer through a hose that drags along the ground.

Research and development

The biogas process is a complex microbiological process with many decomposition steps. Research and development is being carried out, both in Sweden and abroad, to optimize the process and increase the amount of methane that can be extracted. Examples of research topics include studies of the nutritional and environmental requirements of the important microorganisms involved, new substrate mixtures (e.g. seaweed) and pre-treatment technologies (e.g. treatment with enzymes and ultra-sound), different digestion methods (e.g. two-step digestion, dry digestion etc.) and development of measurement and sensor techniques to monitor the status of the process. Fundamental research is mostly carried out at universities, while more applied research is also carried out by companies and research institutes. Research and development work is often carried out in close collaboration with Swedish biogas plants, both in pilot and full-scale experiments. In many cases, biogas plants also pursue their own research and development work to improve the biogas process.

Terminology

Biogas	That gas, which mostly comprises carbon dioxide and methane, which is produced when organic material is decomposed in an oxygen-free environment (anaerobic digestion).
Digestion gas	Biogas that is produced from sewage sludge, manure, agricultural crops etc. in a digester.
Landfill gas	Biogas with a low methane content that is produced from waste heaps and landfills.
Raw gas	Raw biogas, that is unpurified biogas, saturated with water vapour, that comes directly from the plant.
Upgraded biogas	Biogas that has been purified (upgraded) to vehicle fuel quality, with a methane content of at least 95%.
Bio-methane	Generic name for gases in which methane is the main constituent, and which can be extracted from biological material, for example by anaerobic digestion or thermal combustion.
Digestion residue	the solid, liquid or sludge-like product that is formed after digestion, which contains water, undecomposed organic material, nutrients and microbial biomass.
Digestion sludge	The residue obtained from digestion of sewage sludge.
Bio-manure	Digestion residue from biogas plants that digest relatively clean wastes such as manure, source-sorted food wastes, waste from the food industry, agricultural crops etc.
Second generation fuel	Concept without any generally accepted definition, but normally refers to bio-fuels that are extracted with a relatively high net gain of energy from cellulose-rich materials (e.g. forest raw materials) .
Co-digestion	Simultaneous digestion of various substrates, which often produces more methane than if each substrate has been digested separately.

Economic factors

Economic factors controlling the financial viability of biogas (e.g. investment costs, central and local government support via grants etc.) can change significantly with time. This chapter gives an approximate picture of the size of the investment and production costs and the economic incentives and grant support introduced to date. Politicians and other decision-makers should continue to demonstrate their support to ensure the successful development of biogas in Sweden in the future. Construction of a large biogas plant is a significant investment, which to date has required grant support from public funds to ensure financial viability, at least in an initial phase. Central government support in the form of LIP and KLIMP grants has in many cases proved decisive. The establishment of biogas on the Swedish market in the long-term depends on a continuation of this kind of support.

Investment costs

Investment costs for farm-based plants

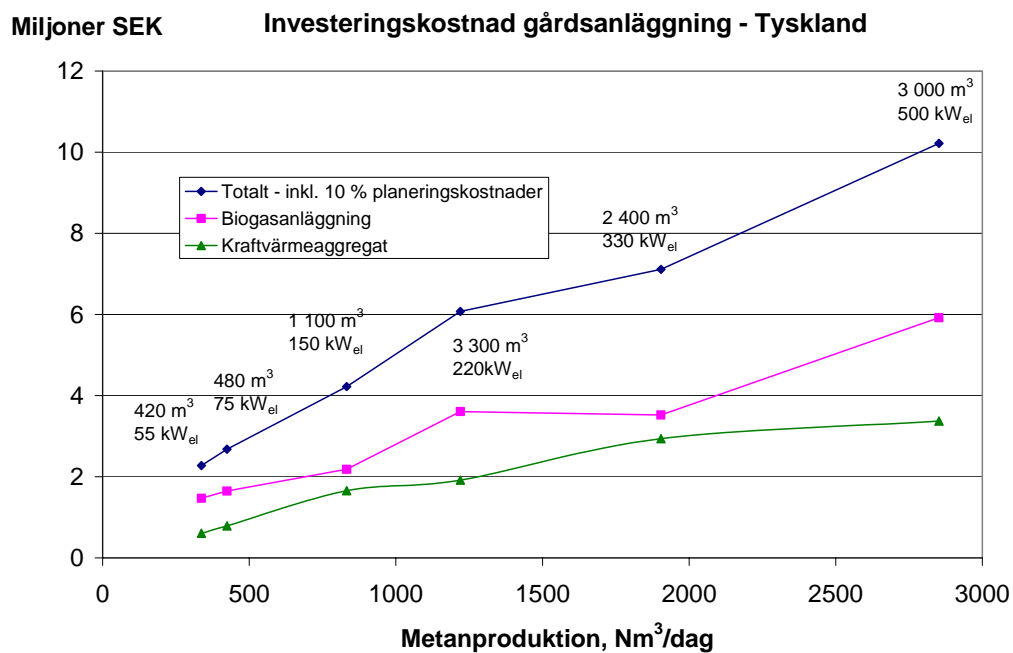

Figure 1 Investment costs for farm-based biogas plants in Germany (Source: SGC)

There are several thousand farm-based biogas plants in Germany. Investment costs for six heat and power producing plants differing in size are summarized in a German handbook on on-farm production of biogas. The plants mainly digest manure and crops grown for bio-energy. The two smallest plants are based on dual-fuel engines, while Otto engines are used in the larger ones. The figure shows the

investment costs divided between the biogas plant and the power and heat plant. These costs are calculated based on the amount of biogas produced in Nm³ per day.

Investment costs for co-digestion plants

Co-digestion plants anaerobically digest mixtures of different types of organic waste, including manure and bio-energy crops. A report which evaluated the investment costs for co-digestion plants (in SEK per ton digested waste per year) was published by 'Avfall Sverige' ('Swedish Waste Management') in 2005. The study was based on four existing plants which only digest pumped waste and a further six plants (one existing and five in the planning stages) that digest semi-solid wastes (e.g. household wastes). Investment costs for plants that digest pumped waste varied between 850 and 1600 SEK per ton of waste. Investment costs for plants that digest semi-solid wastes ranged from 2200 to 8600 SEK per ton of waste.

Investment costs for upgrading plants

Biogas must be upgraded before it can be used as a vehicle fuel or distributed through the gas grid. The investment costs for sixteen upgrading plants (excluding compressors and buildings) were summarized in a report from 'Svenskt Gastekniskt Center' ('Swedish Gas Centre') in 2003. The figure below shows the findings from this study. The investments were made between 1996 and 2006 and the figures shown have not been corrected for this.

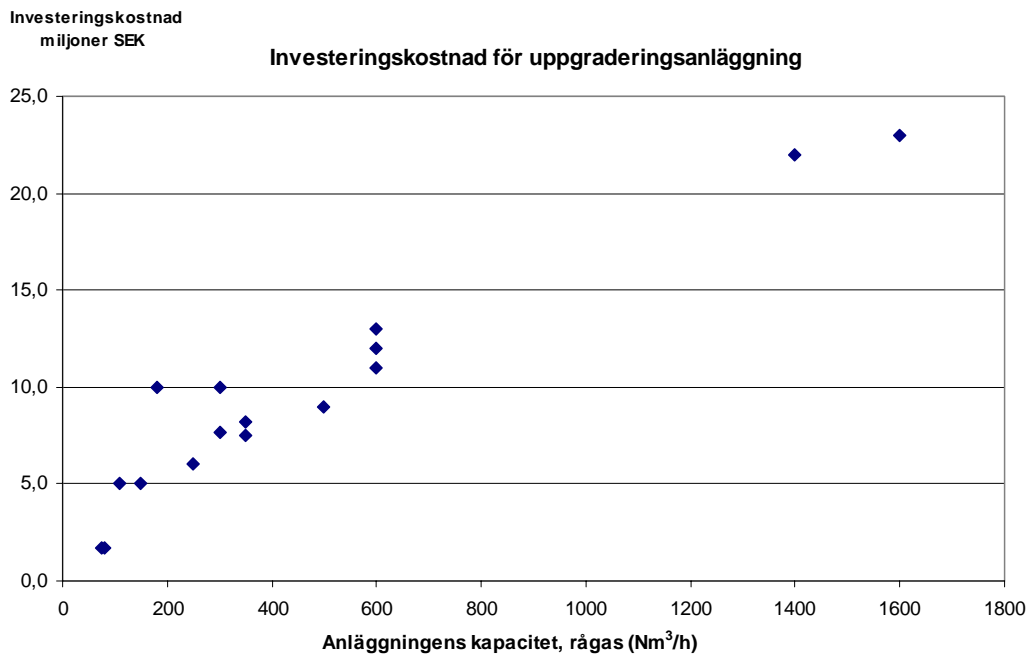

Figure 2 Investment costs for upgrading plants (Source: SGC)

Economic support and incentives

A number of economic incentives and measures have been introduced to meet the political targets that have been set up in relation to energy and climate policy. The most important of these is energy taxation which encompasses energy, carbon dioxide and sulphur taxes. Other important measures include the electricity certificate system, the climate investment and energy efficiency programs, and the trade in emission allowance units. These are described below.

Energy taxation

Initially, the primary aim of energy taxation was fiscal. In other words, it simply contributed to the financing of state expenses. The reason has now changed. Energy taxation now provides the means to manage the production and use of energy to meet current political goals. The tax system today mainly aims to promote energy efficiency and encourage the development and use of renewable energy resources in Sweden. Different fuels are taxed at different rates, depending on the pollutant emissions they give rise to and how they are used.

Biogas is used today either as a vehicle fuel or to generate power and heat. Fossil fuels are liable for carbon dioxide and energy taxes, which the consumer pays. Natural gas used as a vehicle fuel is exempt from energy taxation until 2013. Biogas and other vehicle fuels produced from renewable sources are generally exempt from energy taxation until 2013, and are also exempt from the carbon dioxide tax, since they are carbon dioxide neutral.

Heat production is liable for energy and carbon dioxide taxation and in certain cases charges are also levied for sulphur and nitrogen emissions. On the other hand, consumers are not charged. No energy taxes are charged when biogas is used for heat production, in contrast to oil and coal, where energy taxes of 750 SEK/m³ and 319 SEK/ton are levied. Biogas is also exempt from the carbon dioxide tax, which is not the case for fossil fuels.

Energy and carbon dioxide taxes are not levied on electricity generation. Instead, the consumer is charged a combined electricity tax. In some cases, electricity producers are liable for taxes charged for nitrogen and sulphur emissions. A special system has been introduced (electricity certificates) to encourage the generation of electricity from renewable resources, since the use of tax exemptions on production is not a useable option.

Electricity certificates

A support system based on electricity certificates was introduced in May 2003 to encourage the production of electricity from renewable sources (including biogas). Producers receive one certificate for each MWh of electricity generated from

renewable resources. The certificate can be sold, which generates additional income for the producer. The average price of the certificate in the period 2003-2006 was 0.22 SEK/kWh. At the same time, all electricity consumers (with the exception of some heavy industrial consumers) are required to buy a certain proportion of renewable electricity by purchasing certificates. The cost of the certificates is distributed among the consumers. In 2006, electricity consumers were required to buy in certificates equivalent to 12.6% of the total electricity consumption. The certificate system has been extended to 2030. New plants receive electricity certificates for 15 years.

Economic incentives for biogas vehicle owners

There are certain financial advantages to driving vehicles run on fuels, including biogas, that are derived from renewable sources. Private buyers of biogas cars receive 10000 SEK from the state, and for those driving a company biogas car, the value for taxation purposes is set at 60% of that for petrol-driven cars. Environmentally-friendly cars are exempt from the traffic congestion toll charges in Stockholm, and are allowed to park free of charge in many towns and cities. A gas car is more expensive than conventional petrol-driven cars, but on the other hand, biogas is cheaper than the equivalent amount of petrol or diesel.

Investment support

Investment support for biogas facilities (production and upgrading) has earlier been granted through local investment (LIP) and climate investment programs (KLIMP). Financial support was granted through these programs to local authorities and other interested parties for measures introduced to reduce emissions of greenhouse gases or which contribute to energy savings. KLIMP started in 2003. The program will award up to c. 365 million SEK in 2008, with 1st November as the deadline for applications. The government does not intend to fund this kind of program in the future. The last decisions on KLIMP investments will therefore be taken in May 2008, for applications received in November 2007. At the time of writing, the system for economic incentives is undergoing significant changes, and it is still unclear what changes will be made to the system for investment support.

Case studies of Swedish biogas plants

This chapter describes twelve Swedish biogas plants that digest different kinds of organic material. The plants are divided into four categories. The case studies consist of five co-digestion plants, two sewage treatment plants, three farm-based facilities and two plants at industrial locations. Each section includes a summary of some lessons learned so far.

Co-digestion plants

There are 18 co-digestion biogas plants in operation in Sweden today that treat simultaneously various organic materials. This usually produces more methane than when the individual substrates are treated separately. Raw materials for these processes can include manure, source-sorted food wastes from households, shops and restaurants, crops and waste products from the food industry (e.g. slaughterhouse wastes and various process wastewaters). The first co-digesters were built in the mid-1990's and construction of new plants is continuing today.

These processes are large-scale, with digestion chambers at least 1000 m³ in size, and often up to 3000 to 5000 m³. Most are mesophilic digesters, with process temperatures of c. 35-37°C, although some thermophilic reactors with temperatures of around 55°C are also in operation. At many of these plants, the biogas is upgraded to vehicle fuel quality using various techniques, of which physical absorption (water wash) is the commonest. The bio-manure produced is usually spread on arable land in the vicinity of the plant. This is most often done using conventional spreaders for liquid manure (slurry), but other methods are also employed.

As examples, five co-digestion plants are described in this handbook: Boden, Helsingborg, Kristianstad, Linköping and Västerås. LIP and/or KLIMP funding supported the development of all five of these biogas plants. The biogas plants in Helsingborg, Kristianstad and Linköping have been running commercially for more than ten years, while Boden and Västerås were established somewhat later.

Experiences from co-digestion

The method must be considered relatively new, as large-scale co-digestion plants have only been in operation for c. ten years. All aspects of the technology are continually being developed, from treatment of the raw materials to the final treatment of the biogas and bio-manure.

An important aspect which affects project success is whether the bio-manure that is produced finds a suitable market. Certification is an important tool in this context, since it emphasizes the quality of the final product and also focuses attention on

environmental questions in the whole process from waste management to food production. Certified bio-manure is currently produced from 7 of the 18 co-digestion plants in Sweden. More plants will shortly be joining the system.

The profitability of co-digestion plants depends on a number of factors, many of which are difficult for the plant to control. For example, one important factor is the availability of substrate. Certain substrates, for example, slaughterhouse waste, have a high energy content and are therefore in demand in a competitive market. The price of petrol is an important factor for producers of vehicle gas. It is also critical that all the biogas produced is efficiently distributed. Profitability for a biogas producer also depends on the contracts that are negotiated with companies dealing with waste management and energy production etc. Another important factor affecting profitability is whether there is a market for the bio-manure that is produced. Many of these projects would not have been possible without economic support from LIP and KLIMP. However, in the long-term, these plants are expected to become profitable.

Close collaboration between various partner organisations and individuals is required to ensure that the entire system functions properly, from the supply of substrate to the distribution of biogas and bio-manure. It would be difficult to construct and operate a biogas plant without this co-operation.

Swedish co-digestion projects have attracted a great deal of attention, both nationally and internationally, and these biogas plants receive many visitors each year.

The biogas plant in Boden

Facts/unique: thermophilic (55°C) co-digestion of sewage sludge and food wastes.
First in Sweden to deal with methane leaks during upgrading.



Figure 4.1.1 The biogas plant at Svedjan, Boden

The biogas plant in Boden, which started operating in 2003, can be seen as one result of the focus placed on environmental questions by the local authority since the early 1990's. The biogas produced by the sewage treatment plant at Svedjan was first used only for heating. Biogas production increased when the plant began co-digesting sludge with food wastes. The objective was to make more efficient use of the energy in the biogas. Plans to use the biogas as a vehicle fuel were finally realised within the framework of the KLIMP program. In the spring of 2007, Sweden's and the world's most northerly upgrading plant and filling station for biogas was ready to begin operation.

More methane can be extracted by co-digesting sludge and source-sorted household waste, than when sludge is digested alone. In turn, this results in a greater production of biogas, which supplies Boden's filling station with environmentally-friendly fuel. It is important from a strategic point of view that biogas as a vehicle fuel is also produced in northern Sweden. Together with Östersund and Skellefteå, Boden has led the way by establishing the first upgrading plants north of Uppsala. More local authorities in northern Sweden are now ready to follow Boden's example.

The biogas plant and substrate

The biogas facility at Svedjan co-digests sewage sludge from eleven sewage treatment plants run by the local authority and c. 1200 individual septic tanks with

source-sorted food waste from households, restaurants and shops. The food waste is chopped and mixed with the sludge in a ‘pulper’. The mixture is pasteurized at 70°C for one hour before it is pumped into the reactor, which has a volume of 1300 m³. The process is thermophilic, with a temperature of 55°C and a retention time of between 14 and 16 days.

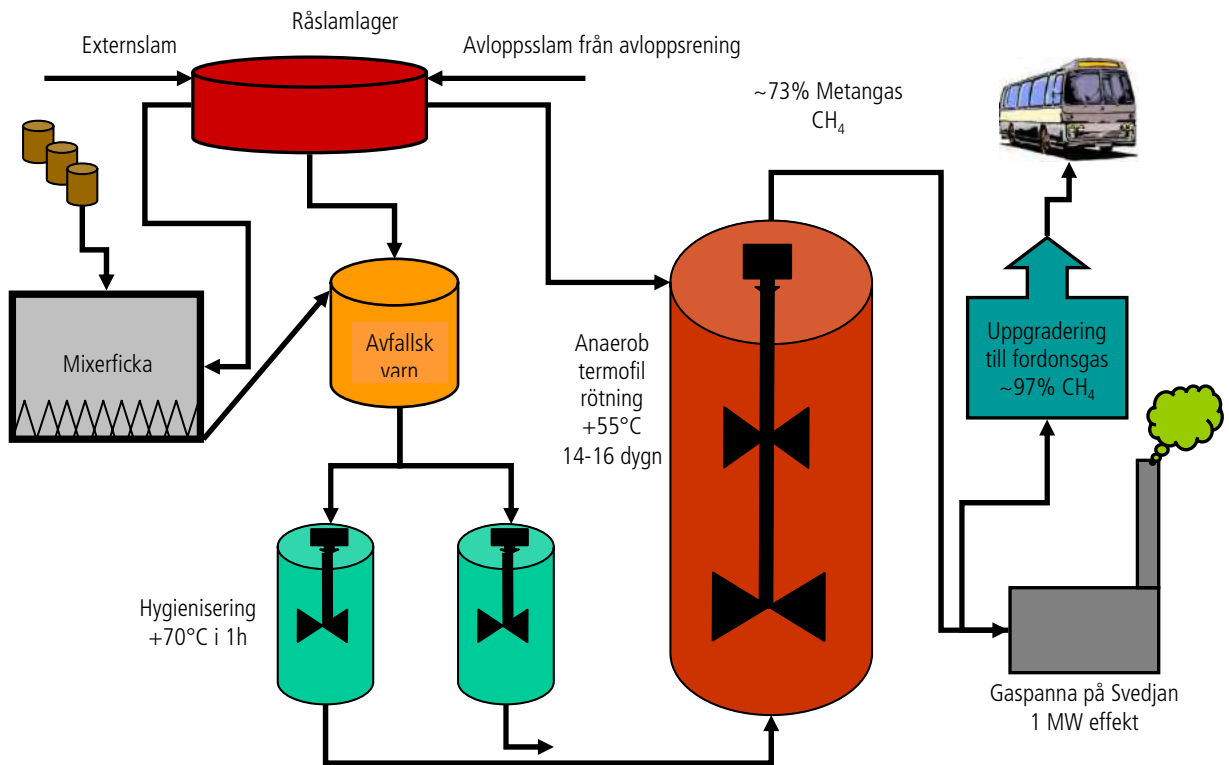

Figure 4.1.2 Diagram of the biogas plant in Boden

Upgrading and use of the biogas

Some of the biogas was previously combusted in a boiler to heat the plant buildings. The excess heat (c. 3000 MWh) was distributed through the district heating network in Boden. Since the upgrading plant (of the water wash type) started operation, some of the biogas is now converted to vehicle fuel. The upgrading plant at Boden was the first in the country to deal with leaks, which amount to c.3% of the methane produced. The leaks are made harmless by catalytic combustion. The excess energy is used to heat buildings. This new technology reduces methane leakage to c. 0.1%. In step with increasing demand, the plant can produce c. 600,000 Nm³ of vehicle gas annually, which replaces roughly 0.7 million litres of petrol.

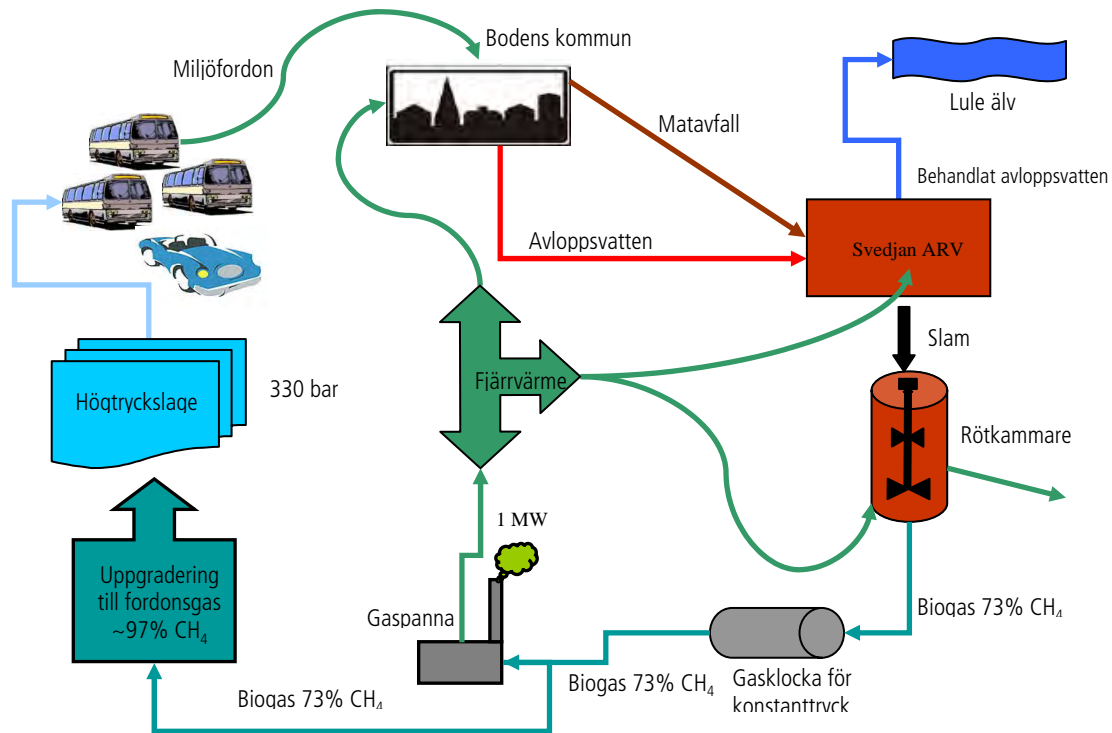

Figure 4.1.3 Biogas and vehicle fuel are produced from sewage sludge in Boden

Distribution of the biogas

High pressure compressors, gas storage tanks and filling equipment are located c. 500 m from the sewage treatment plant. The gas is transported under a pressure of 10 bars in a pipe 250 mm in diameter. The gas is stored in containers at three different pressures in the proportions 1:2:3, with the high pressure containers (330 bars) as the smallest storage. The liquid volume is c. 26 m³ which implies a gas volume of c. 6000 Nm³. The dispenser at the filling station has two different mouthpieces, one for quick filling of heavy vehicles and one for cars. Another dispenser is also planned. There is also a possibility to fill up from two containers. In the near future, the biogas from the Svedjan plant will support 6 buses, 3 heavy vehicles and 150 local authority- or privately-owned cars.

Digestion residues

The digestion residue (c. 1600 tons per year) is used to produce filling material and soil conditioner. In the future, a range of different products may be developed (e.g. forest pellets) based on the digestion residue. The residue is de-watered by centrifugation to a dry weight of c. 30%. The residue is stored in silos and transported by truck (c. 30 tons for each transport).

Financing

The investment costs for stage 1 (the digester and the pre-treatment facility for food wastes) were 26.8 million SEK. Of this, LIP contributed 10.4 million SEK. The total

investment cost for stage 2 (the upgrading plant and filling station) was 19.5 million SEK. Of this, KLIMP contributed a little more than 8.3 million SEK. The net investment was therefore 27.6 million SEK, which means that the annual capital cost is c. 2.5 million SEK. Both investments are economically viable for the following four reasons:

- A. the amount of sludge produced by sewage treatment has halved, which means that transport costs have decreased by c. 0.5 million SEK per year.
- B. The local authority can treat food wastes in their own facility. The cost is calculated at c. 200 SEK per ton, which can be compared with the cost of composting, which is calculated at 700 SEK per ton. The savings are estimated at 1 million SEK per year.
- C. The net income from the sale of vehicle gas, when full production is reached in a few years, will be c. 3.5 million SEK per year. This calculation assumes that the biogas is not used to heat the plant.
- D. The plant has the capacity to accept and treat 1000 tons of food waste from other sources, which will give an income of c. 0.5 million SEK per year.

In total, the savings will be of the order of 3 million SEK per year, which means that the investment will be repaid within a 10-year period.

Lessons learned

Construction has largely gone according to plans. However, stage 1 was delayed for a little more than a year because the legal decision to approve construction was appealed. In the planning and construction phases, it is important to carefully select the substrates that the plant will treat. Problems can occur with the quality of the food waste, either because of mistakes in source-sorting or during transport. The concept can therefore be recommended for future biogas producers, providing that the quality of the food waste can be guaranteed. The upgrading plant is working especially satisfactorily.

Benefits for the environment and society

Emissions of carbon dioxide from the Boden area have decreased by a little more than 1400 tons per year as a result of the development of biogas. The filling station for biogas is easily accessible and the local authority encourages the purchase of biogas-driven cars. For example, local inhabitants have been offered 800 Nm³ of free gas in 2008 if they invest in a biogas car.

The establishment of more filling stations in the northern counties is strategically important for the development of biogas in Sweden as a whole. Apart from the existing public filling stations at Boden and Östersund, Skellefteå will soon open a biogas station, and Sundsvall will follow within a few years. The Swedish Environmental Protection Agency has approved grants to the gas supply company

'Fordonsgas' to open filling stations for vehicle gas in a number of towns along the coast of northern Sweden.

Construction of the biogas plant at Boden has reduced the amount of organic waste that was earlier deposited in landfills by c. 5000 tons per year. Anaerobic digestion has reduced the volume of sludge, which in turn has decreased the number of truck journeys by c. 700 per year. New technology is used to deal with methane leaks at the upgrading plant, which means that emissions of this greenhouse gas to the atmosphere are now negligible. Construction of the plant created employment, and one new position was created to run the plant.

Facts 1. Basic data on the biogas plant

Start year (biogas production):	2003
Digester volume	1 300 m ³
Process temperature:	55 °C
Start year (upgrading):	2007
Upgrading method:	Water wash
Total investment costs:	46.3 million SEK

Facts 2. Yearly input & outputs

Substrate:	
Source-sorted food wastes	1 200 tons
Sewage sludge	24 000 tons (960 tons dry weight)
Biogas:	
From sewage sludge	2500 MWh
From food wastes	3 000 MWh
To local heating	3 500 MWh
Distributed through heating network	1 600 MWh
Upgraded biogas	400 MWh
Digestion residue:	
Filler material in construction	1 000 tons
Soil conditioner	600 tons

Contacts

	www.boden.se Ove Andersson Telephone: +46 921 621 78 E-mail: ove.andersson@boden.se
--	--

Suppliers

Biogas plant:	Läckeby Water AB www.lackebywater.se
Upgrading plant, storage tanks and filling station:	YIT Vatten och miljöteknik AB www.yit.fi

The NSR biogas plant in Helsingborg

Facts/unique: Biogas to the gas grid and piped bio-manure. Initiator of the bio-manure certification system.



Figure 4.2.1 Hose spreader for spreading liquid manure, Helsingborg

The NSR biogas plant in Helsingborg started operations in 1996. NSR is a regional waste recycling company owned by six local authorities in north-west Skåne (Bjuv, Båstad, Helsingborg, Höganäs, Åstorp and Ängelholm). The original driving force behind the development of the biogas plant was the need to treat various organic wastes that were unsuitable for landfilling. Nowadays, the production and refinement of biogas as an alternative vehicle fuel is an additional motivation.

Several improvements and extensions to the biogas production and distribution systems have been made since 1996. Upgrading of biogas started in 1997. Work on expanding the original biogas plant to double its capacity began in 2006 and was completed by the summer of 2007. The capacity of the upgrading plant has also been increased. 'NSR Bio-manure' started marketing bio-manure to agriculture as

early as 1997 and its quality is nowadays recognized under the certification system. A pipeline was laid in 2006 to pump it directly out to the fields.

Food wastes represent a relatively large proportion of the substrate digested in the reactors, and the pre-treatment of this kind of waste has been continuously developed during the life-time of the plant. A new pre-treatment facility for food wastes and packaged food will start operations in the summer of 2008. There are also plans to use dry digestion to treat the remaining material after removing the pure food waste and packaging materials. NSR has also been innovative with respect to the distribution of bio-manure and was one of those responsible for the establishment of the certification system for bio-manure according to SPCR 120 regulations. NSR also has an advanced system for collecting landfill gas at the Filborna landfill, and is participating in an international research project in which new methods will be developed to detect methane losses from landfills.

The biogas plant and substrate

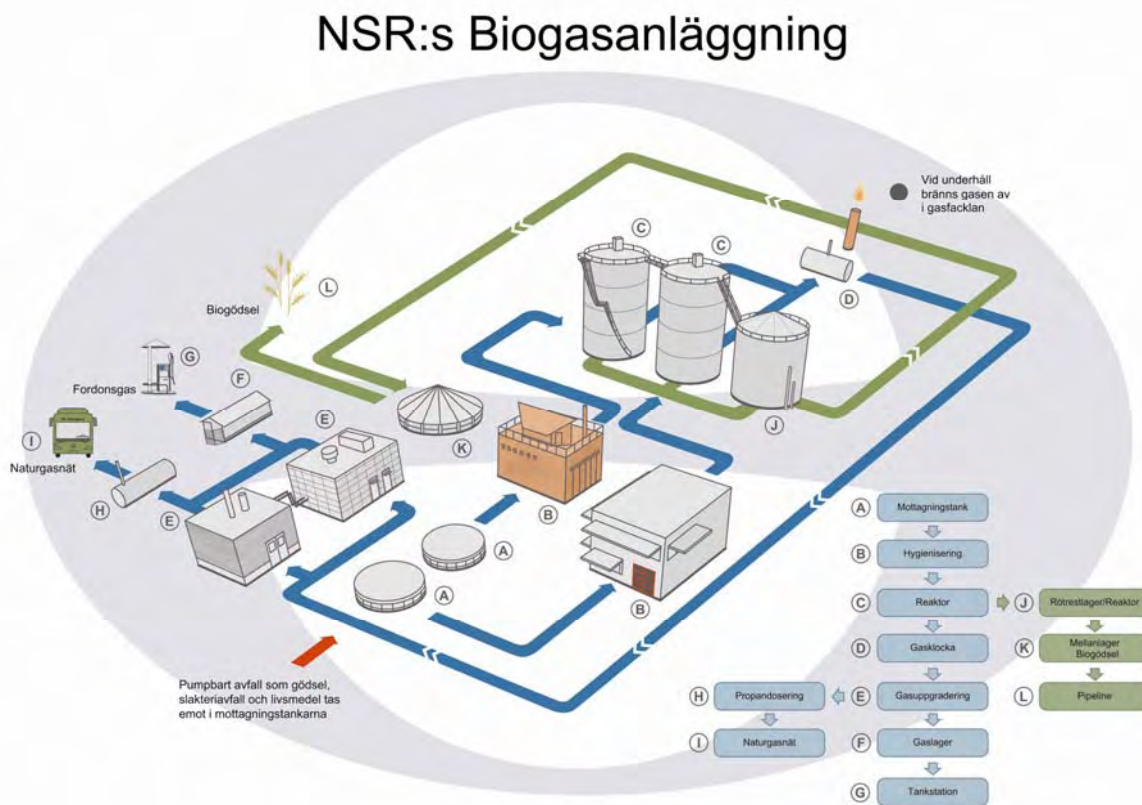

Figure 4.2.2 Diagram of the biogas plant at NSR, Helsingborg

The raw materials consist of process waste from the food industry, fresh pig manure and source-sorted food wastes. The plant is designed to accept up to 80,000 tons per year of different kinds of waste, including waste that can be pumped, and source-sorted and compressed food waste and packaged foods. Contracts have been drawn up with local farmers and food manufacturers to ensure a constant supply of

substrate to the biogas plant. Two tanks, each 1000 m³ in size receive the waste, which is first chopped and mixed. The material is then pasteurized in three separate tanks at 70°C for one hour. The heat is supplied by a wood-burning furnace. A compost filter removes odours during the pre-treatment. The one-step process takes place in two mesophilic (37°C) reactors, each 3000 m³ in size, with a retention time of c. 30 days. There is also an additional digestion chamber (1000 m³) where material is stored prior to distribution.

Upgrading and use of the biogas

In 2007, the plant produced c. 23,000 MWh of raw biogas. Production is expected to increase significantly in 2008, since the plant was extended in 2007. All the biogas is upgraded to vehicle fuel quality. The first pilot-scale upgrading plant was built in 1997. This was replaced in 2002 with a full-scale plant, while the pilot-scale plant was moved to Växjö. Both upgrading plants used the PSA method. Another upgrading plant was built in 2007, this time with the water wash technique. The methane content after upgrading is 98%. About 12,000 MWh of upgraded biogas was produced in 2007. The total production capacity is more than 40,000 MWh.

Distribution of the biogas

The upgraded biogas is dried, compressed to a pressure of 280 bars and stored in canisters. The store holds c. 7000 m³ of biogas. Some of this gas is sold in NSR's public filling stations located at Filborna re-cycling plant, and is also used to run refuse lorries. However, most is distributed through the gas grid and is used to run buses. Propane is added to this gas to give it the same energy content as natural gas. In total, the biogas produced by NSR runs 100 buses, 20 refuse lorries and a large number of cars both locally and regionally.

Bio-manure

The quality of NSR's bio-manure has been certified since 2003. In 2007, 44,000 tons of bio-manure was produced at the plant. Of this amount, 20,000 tons are pumped through a 10 km long pipeline to ten farmers who are participating in the project. In a few years, the capacity of this pipeline will double. The bio-manure is stored in four tanks prior to spreading with mobile spreader equipment and feeder hoses.



Figure 4.2.3 Map of the bio-manure pipeline

Financing

So far, 120 million SEK has been invested in the biogas plant, including the systems for the distribution of biogas and bio-manure. The plant built in 1996 was self-financed. Since then, NSR has received a little more than 19 million SEK in KLIMP grants for various extensions and improvements, some of which are still underway. Amongst other items, NSR has obtained KLIMP grants for the pipeline for bio-manure, the development of a dry digestion technique, the purchase of new gas-driven vehicles and to increase the capacity for biogas production at the plant. In the long-term, NSR's biogas project will be a profitable investment.

Lessons learned

The extensions to the systems for biogas production and distribution of both biogas and bio-manure have gone according to plan. Competition for substrate in the region is one problem that is sometimes experienced. It is therefore important at the planning stage to carefully investigate the availability of substrate. A market for the bio-manure is another critical factor. The certification system has been an important factor in this respect, since it has enabled the application of bio-manure to agricultural land. The location of the biogas plant must also be chosen carefully, both with respect to logistics and the avoidance of odour problems.

Benefits for the environment and society

The biogas produced in 2007 replaced more than 1.3 million litres of petrol and thereby reduced carbon dioxide emissions by 2800 tons. The increased capacity of the plant is expected to result in even greater benefits for the environment in 2008. Large parts of the plant were built with re-cycled construction materials. For example, two of the reactors came from the old sugar refinery in Hasslarp. The bio-manure pipeline has reduced truck traffic by c. 22,500 km each year. This figure will double when the pipeline capacity increases in a few years time. This will reduce the annual emissions of fossil carbon dioxide by 78 tons. An important issue for the agricultural industry is whether the bio-manure is approved for application on land that is used to produce food. Certification guarantees the farmer that NSR's bio-manure is hygienic, has a high nutrient content, and that the contents of heavy metals are below allowable limit values.

Facts 1. Basic data on the biogas plant

Start year (biogas production):	1996
Digester volume:	2 x 3 000 m ³ , 1 x 1 000 m ³
Process temperature:	37 °C
Start year (upgrading):	1997, 2002 and 2007
Upgrading method:	PSA and Water wash
Total investment costs:	120 million SEK

Facts 2. Yearly inputs & outputs

Substrate:	
Source-sorted organic food wastes	5 600 tons
Pig manure	3 400 tons
Process wastes from food industry	35 200 tons
Biogas:	
From the biogas plant	23 000 MWh
Upgraded biogas	12 000 MWh
Bio-manure:	
Total bio-manure	44 000 tons
Bio-manure in pipeline	20 000 tons

Contacts

	www.nsr.se Karin Eken Södergård, Product Manager Biogas Telephone: +46 42 400 13 35
--	--

	E-post: karin.eken@nsr.se Jessica Cedervall, Section Manager, Biological Treatment Telephone: +46 42 400 13 53 E-mail: jessica.cedervall@nsr.se
--	--

Suppliers

Biogas plant:	Malmberg www.malmberg.se AnoxKaldnes www.anoxkaldnes.com
Upgrading plant:	Läckeby Water www.lackebywater.se Biomil www.biomil.se
Bio-manure pipeline:	Oden entreprenör AB www.odan.nu
Manure tanks:	Abetong www.abetong.se

The biogas plants in Kristianstad

Facts/unique: Collaboration between partner organisations and individuals, complete biogas system. First in Sweden to co-digest food wastes, manure etc.

One important driving force for the construction of the biogas plant at Karpalund in Kristianstad was the need for local food-processing plants to treat their waste. In addition, the local authority was introducing a new system for household waste collection, and they wanted to develop appropriate treatment methods for the resulting source-sorted food wastes. The new biogas plant in Karpalund, run by a waste management company owned by the local authority, started operations in December 1996. In the mid-1990's, the question was also raised as to how to make better use of the biogas produced at the sewage treatment plant that had, up to that time, been 'flared off'. At the same time, discussions began on the best way to use

the biogas produced at Karpalund in the long-term. All this finally led to the construction of the first stage of a new upgrading and distribution system for biogas. The first upgrading plant, located at the sewage treatment plant, opened in 1999 and is run by the technical office of the municipality of Kristianstad (C4 Teknik).



Figure 4.3.1 The biogas plant at Karpalund, Kristianstad

Several new investments were made in the following years to extend the biogas system in Kristianstad. These investments increased the capacity of the biogas plant, while an additional upgrading plant opened in 2007. The system is still being extended. For example, a KLIMP grant has been received to build a new biogas reactor at Karpalund to replace one of the older reactors, which will instead be used as an intermediate storage facility for the digestion residues. A new facility for the pre-treatment of agricultural crops is also planned, and two gas turbines will be installed to generate electricity from the biogas.

One of the strengths of the biogas project in Kristianstad is the number of co-operating partners involved. Thus, households and the agriculture and food industries co-operate by delivering substrate to the biogas plant. Production and distribution of the gas is carried out in a collaboration between the local authority, the energy company Eon, and the bus company, Skånetrafiken. The plant at Karpalund was the first in Sweden to co-digest source-sorted household waste, manure and food industry wastes. Kristianstad now has a complete biogas system with two production plants, two upgrading facilities, its own pipeline distribution system for biogas and several filling stations. Landfill gas from the Härlövs landfill

is also collected and used. Kristianstad is working towards the long-term goal of becoming a municipality which does not consume fossil fuels.

The biogas plant and substrate

The biogas plant at Karpalund has two reactors, 4000 and 4500 m³ in size. The process is mesophilic (38°C), and the reactors are continuously mixed one-step processes with a retention time of 22 days. The substrate consists of source-sorted household waste collected in paper bags, liquid manure and slaughterhouse, distillery and dairy wastes. The plant has a capacity to treat 80,000 to 100,000 tons of raw waste per year. The new reactor will increase the capacity to 150,000 tons per year. The food waste is first chopped and then mixed with the remaining substrate. The raw material first passes through a magnetic separator and a fine mill on its way to the mixing tank where it is stored for 3 to 7 days before further treatment. Prior to digestion, the material is heated and pasteurized at 70°C for at least one hour in three parallel tanks.

Upgrading and use of the biogas

The biogas plant at Karpalund produces c. 40,000 MWh of biogas per year, and the sewage treatment plant contributes a further 6,000 MWh. Both upgrading plants employ the water wash technique. In 2007, Eon bought 13,300 MWh of biogas as vehicle fuel, equivalent to more than 1.4 million litres of petrol. The production of upgraded biogas is expected to increase in the coming years. Some of the biogas is used for heating. The gas being produced at the disused landfill at Härlövs near Kristianstad has also been collected since 1989 in a comprehensive pipe system. Until 1995 the gas was flared off, but since then it has been used as a fuel in the municipal power station (Allöverket).

Distribution of the biogas

The biogas produced at the Karpalund plant is led through pipelines to the sewage treatment plant and to Allöverket for upgrading. The gas pipe network in Kristianstad has a total length of 10 km. The first public filling station opened in 1999 at the sewage treatment plant. A common bus depot for Skånetrafikens entrepreneurs opened in 2002 at Allöverket. Another filling station for biogas opened in 2004 in northern Kristianstad.

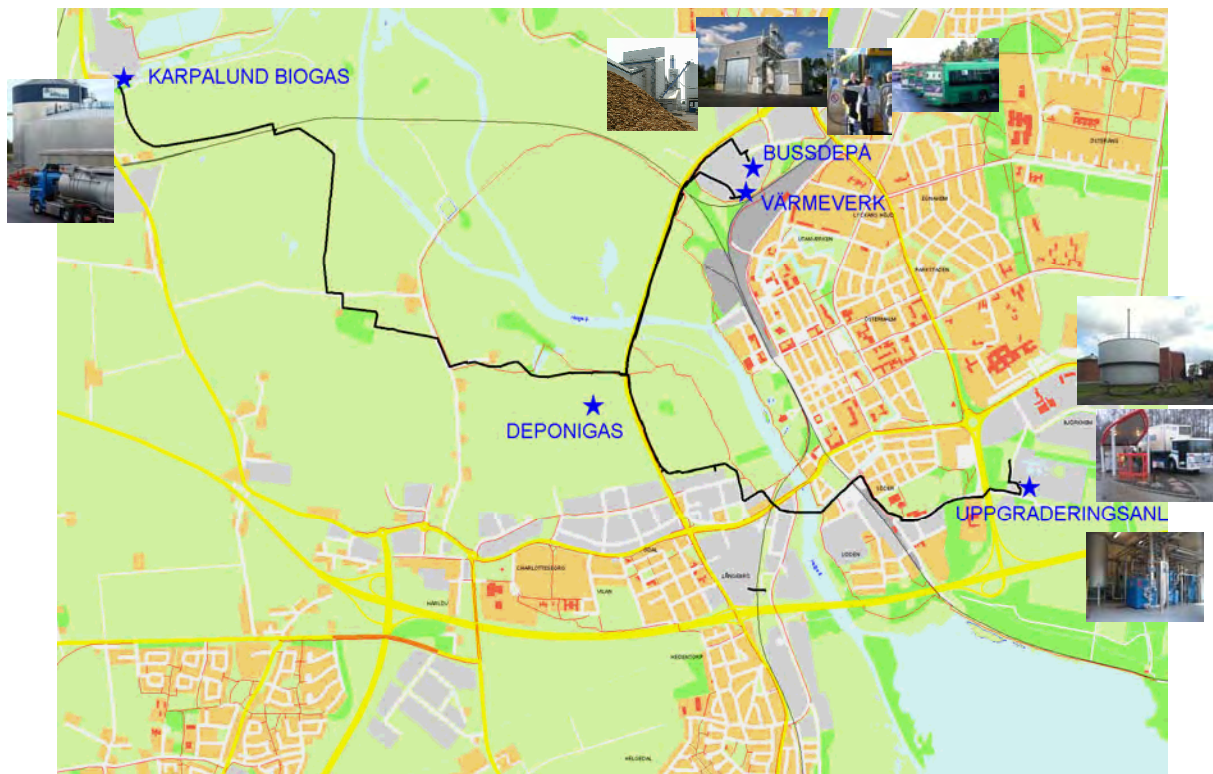

Figure 4.3.2 Map of biogas distribution, Kristianstad

Bio-manure

After digestion, the bio-manure passes through two screw sieves where undesirable materials such as plastics and coarser particles are removed. The bio-manure is de-watered and the excess water is returned to the reactor. The bio-manure is stored in a closed gas-tight tank which is mixed. The certified bio-manure is spread on nearby agricultural land owned by farmers who supply manure as raw material to the plant. Each ton of bio-manure contains 55 kg of nitrogen (43 kg as ammonium), 4.5 kg of phosphorous and 16.5 kg of potassium.

Financing

The total investment cost to date is c. 107 million SEK, which has been partly financed through state grants (19 million SEK), mainly from LIP and KLIMP. The development of biogas in Kristianstad will be economically viable in the long-term, given that the demand for alternative fuels is continually increasing.

Lessons learned

Collaboration with farmers has been of strategic importance for the development of the project. It would be difficult to construct and operate a biogas plant without this co-operation. Policies adopted by the local authority in Kristianstad to reduce the consumption of fossil fuels have also played an important role, especially the environmental policy adopted in 1998, the declaration of intent to become free of fossil fuels which followed a year later, and the climate strategy which was adopted

in 2005. These policies have been adopted with complete political consensus, which is also an important factor. The collaboration between the various partners participating in the biogas project has been successful.

Benefits for the environment and society

The development of biogas has improved the local environment in Kristianstad. For example, the air has become cleaner as fossil fuels are replaced by biogas. Carbon dioxide emissions have been reduced by more than 11,000 tons of carbon dioxide equivalents per year. In 2007, more than 1.4 million litres of petrol were saved and this figure is expected to increase in the coming years. Incineration of organic wastes has decreased by 40,000 tons per year.

Many actors participate in the biogas project, which has strengthened links between the town and the surrounding rural areas. Information campaigns have increased the environmental awareness of the local population. They are also encouraged to drive biogas vehicles. For example, the local authority awards local 'climate grants' to companies and public establishments that buy gas vehicles. Their owners can also park free of charge in municipal car parks. A car pool for environmentally-friendly cars, the definition of which includes biogas cars, has also recently started.

Together with Linköping, Kristianstad has the most complete biogas system in the world. The production of biogas exceeds local consumption, so Kristianstad has become an exporter of biogas, supplying filling stations in Hässleholm, Olofström and Ystad. The development of biogas in Kristianstad will be further strengthened by the opening of new filling stations in the surrounding region. A denser network of filling stations will make it even more attractive to buy biogas cars, which will further benefit the environment.

Facts 1. Basic data on the biogas plant

Start year (biogas production):	1996
Digester volume:	4 000 m ³ and 4 500 m ³
Process temperature:	38 °C
Start year (upgrading):	1999 and 2007
Upgrading method:	Water wash
Total investment costs:	107 million SEK

Facts 2. Yearly inputs and outputs

Substrate:	
Source-sorted food wastes	5 500 tons
Slaughterhouse waste	35 000 tons
Liquid manure	22 000 tons

Others	10 000 tons
Biogas:	
From the biogas plant	40 000 MWh
From the sewage treatment plant	6 000 MWh
Upgraded biogas	13 300 MWh
Bio-manure:	
Liquid bio-manure	63 000 tons

Contacts

	<p>www.kristianstad.se/biogas</p> <p>Lennart Erfors, Office of the Local Authority Telephone: +46 44 13 61 60 E-mail: lennart.erfors@kristianstad.se</p> <p>Christer Johansson, Karpalunds Biogas plant Telephone: +46 733 13 48 99 E-mail: Christer.Johansson@kristianstad.se</p> <p>Roland Nilsson, Eon Telephone: +46 705 59 39 64 E-mail: roland.nilsson@eon.se</p> <p>Patrik Lindblom, Office of the Local Authority Telephone: +46 44 13 55 93 E-mail: patrik.lindblom@kristianstad.se</p>
--	--

Suppliers

Biogas plant:	Krüger A/S www.kruger.se
Upgrading plant:	Malmberg www.malmberg.se

The biogas plant in Linköping

Facts/unique: Effective process with high methane production.
 The Biogas train, Amanda.



Figure 4.4.1 Biogas car in front of the biogas plant in Linköping

Discussions began in the early 1990's in Linköping on how to reduce emissions of exhaust pollutants from buses in the town centre. Various alternative vehicle fuels were compared. At the same time, the local slaughterhouse was experiencing problems dealing with waste, and large quantities of manure were also available from local farms. Linköping Biogas AB was formed in 1995 in a collaboration between the Technical Office of the local authority, the co-operative agricultural company 'Swedish Meats', Konvex and LRF (the national farmers association) through the company 'Lantbrukets Ekonomi AB'. A pilot biogas project was carried out between 1990 and 1994. Following an evaluation, a full-scale biogas plant was built at Åby, near Linköping, which started operating in spring 1997.

In 2004, the Technical Office became sole owner of the plant and Linköping Biogas AB changed their name to 'Svensk Biogas i Linköping AB' (Swedish Biogas in Linköping). The biogas was upgraded right from the beginning, to use as a vehicle fuel for the city buses. The first public filling station in Linköping for biogas was opened in 2001, and several more have opened since. A number of improvements and extensions to the biogas plant and distribution system have been made since 1997, which have increased the production and use of biogas.

'Svensk Biogas i Linköping' were among the first in Sweden to upgrade biogas to vehicle fuel quality. Significant developments to the process have taken place during the eleven years that the plant has been in operation. The biological process has been specially adapted to enable the digestion of substrate comprising large amounts of slaughterhouse wastes that are rich in energy and proteins. Up to 1000 m³ of methane is extracted per ton of organic material. The process has been stable for many years, despite high contents of nitrogen in the form of ammonium (5.1 g per litre) and a relatively high pH (8). Svensk Biogas have also received attention as a result of the biogas train (Amanda), which has been running between Linköping and Västervik since April 2006.

The biogas plant and substrate

The substrate, which totals c. 45,000 tons per year, consists of c. 55% waste products from slaughterhouses and 45% of other food wastes. The slaughterhouse waste is finely ground and mixed with the other substrates in a homogenizing tank. The substrate is then pasteurized by heating with steam to 70°C for one hour. The material is then cooled before being pumped into the two reactors, each of which has a volume of 3,800 m³. Decomposition takes place at 38°C in a continuously mixed one-step process with a retention time of 30 days.



Figure 4.4.2 Aerial photograph of the biogas plant in Linköping, with a schematic diagram of the plant

Upgrading and use of the biogas

All the biogas produced at Åby is upgraded to use as vehicle fuel. As early as 1992, some of the biogas produced at the town sewage treatment plant was upgraded in a smaller plant (capacity 150 Nm³ biogas per hour) using the PSA technique. This supplied five town buses with biogas fuel. A new upgrading plant based on the water wash method opened in 1997. It has a capacity to upgrade 500 Nm³ biogas per hour. A third plant, using the same technique, was built in 2002, with a capacity of 1,400 Nm³ biogas per hour. Including the gas from the sewage treatment plant, approximately 65,000 MWh of upgraded biogas is produced each year, which supplies fuel to the town's buses, refuse lorries and a number of filling stations in the region. A train (Amanda) was converted from diesel to biogas in 2006. The train operates on the line between Linköping and Västervik and can run 600 km on one tank.

Distribution of the biogas

The three upgrading plants are all located at the biogas plant in Åby. The upgraded biogas is distributed through 8 km of buried pipelines under a pressure of 4 bars to the bus depot and to public filling stations in the area. At the bus depot, the gas is pressurized to 250 bars, and the buses are filled slowly overnight. Svensk Biogas own and run thirteen different biogas filling stations in Linköping and the surrounding region.

Bio-manure

After digestion, the bio-manure is cooled to 20°C and storage in a tank before being delivered to 30 farmers in the surrounding area. Roughly 45,000 tons of bio-manure is produced annually (figure from 2007). The bio-manure has a dry weight content of 4.2% and a nitrogen content of 6 kg per m³ and is certified according to SPCR 120. The bio-manure is spread with conventional techniques for liquid manure application.

Financing

Roughly 130 million SEK has been invested in the construction of production and distribution systems for biogas in Linköping. Most of this was self-financed, although grants from LIP and KLIMP have been obtained on a number of occasions (c. 17 million SEK in total). These grants were used to finance improvements to the biogas and upgrading plants as well as investments in new gas filling stations and vehicles. The biogas project in Linköping will be economically profitable in the long-term.

Lessons learned

One significant change that has taken place is the availability of raw materials and their price. When the plant in Linköping started production in the 1990's, as one of only a few in Sweden, few difficulties were experienced in finding suitable raw

material to fill the reactor. Many local authorities in Sweden are now developing biogas plants, which of course increases competition for organic wastes. Svensk Biogas has therefore decided on a different concept for a new biogas plant being planned in Norrköping. Initially, biogas will be produced from agricultural crops, and in a second phase, the process will be adapted to treat as many different types of materials as possible. It is therefore recommended that organisations planning to develop a biogas plant should investigate the local market for organic wastes to determine the most suitable materials that will guarantee a reliable supply and profitability.

With respect to the biogas process itself, Linköping has put a lot of effort into extracting as much methane as possible from the added substrate. A close collaboration with Linköpings University has played an important role in the development of the process. Support from the local authority is important in any effort to establish biogas, for example by encouraging the purchase of biogas vehicles. A secure home market in terms of biogas-driven town buses and refuse trucks can be critical for success.

Benefits for the environment and society

The biogas plant in Linköping has been successively extended and improved to meet the continuously increasing demand in the region for renewable energy resources such as biogas. Total emissions of fossil carbon dioxide have decreased by more than 9,000 tons per year. Since 2002, all town buses are run on biogas and the air in Linköping town centre has become much cleaner, being almost free of particulate matter and sulphurous and nitrogenous compounds. In 2006, biogas accounted for 6% of the total fuel consumption in Linköping.

A great deal of effort has been put into optimizing the process, with the result that a planned third reactor is no longer necessary. Instead, the capacity of the existing plant has increased, partly by adapting the microbiological process, and partly by adjusting the substrate mixture. The proportion of energy-rich slaughterhouse waste in the substrate has successively increased, replacing manure.

Environmental issues have also received attention at the plant. For example, odour problems have been reduced by installing a compost filter and a biological reactor to treat wastewater from the upgrading plant. In addition, an 'odour panel' has been set up, consisting of 25 persons living in different parts of Linköping. These various measures have significantly reduced odour problems at the plant.

The biogas train is another example of the environmental benefits of biogas. The train was earlier driven on diesel, and the conversion to biogas has reduced emissions of greenhouse gases to near zero. Conversion to biogas was considerably

cheaper than the alternative, which was to electrify the line between Linköping and Västervik.

Faktaruta 1. basic data on the biogas plant

Start year (biogas production):	1997
Digester volume:	2 x 3 800 m ³
Process temperature:	38 °C
Start year (upgrading):	1992, 1997, 2002
Upgrading method:	Water wash and PSA
Total investment costs:	c. 130 million SEK

Facts 2. Yearly inputs and outputs

Substrate:	
Slaughterhouse waste	22 000 tons
Food wastes and others	23 000 tons
Biogas:	
Upgraded biogas	65 000 MWh
Heat	1 600 MWh (newly installed, estimate)
Bio-manure:	
Certified bio-manure	45 000 tons

Contacts

	<p>www.svenskbiogas.se</p> <p>Peter Johansson Telephone: +46 13 20 90 72 E-mail: peter.johansson@svenskbiogas.se</p> <p>Marie Pihlström Telephone: +46 13 20 91 09 E-mail: marie.pihlstrom@svenskbiogas.se</p>
--	---

Suppliers

Biogas plant	Läckeby (now PURAC AB) www.purac.se
Upgrading plants	<p>Carbotech www.carbotech.com</p> <p>YIT Vatten och miljöteknik AB (finns ej kvar) www.yit.fi</p>

	Flotech www.flotech.com
Filling stations	Processkontroll www.processkontroll.com
Gas pipelines	Stadspartner www.stadspartner.com

The biogas plant in Västerås

Facts/unique: cooperation between interested partner organisations and individuals, with farmers participating actively in the project. The project is explained as a ‘mechanical cow’, which has been constructed to supply nutrients and organic matter to agriculture.

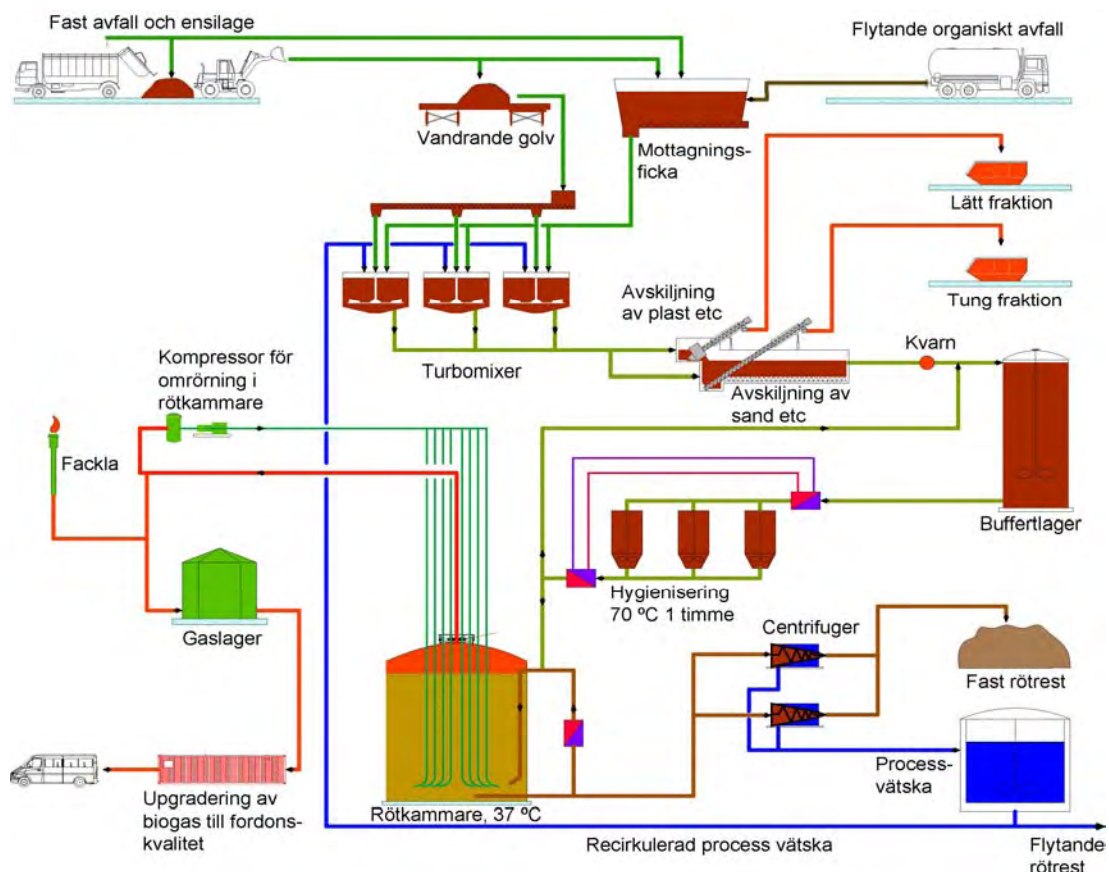

Figure 3.5.1 Diagram of the biogas plant at Gryta, Västerås

The ‘Plant Power’ project in Västerås was conceived in 1990 by some farmers in the district. Many farms in the area have no animals, so that their soils do not receive manure. Manure provides nutrients and humus, as well as contributing to an

improved soil structure. The farmers were advised to supply nutrients to the soil by applying mineral fertilizer. At the same time, a waste management company in the region, VafabMiljö, was planning to expand the biological treatment of food wastes from households and restaurants.

In 1995, the first plans were drawn up for a biogas plant that would digest both agricultural crops and household organic waste in the same process. The company 'Svensk Växtkraft AB' ('Swedish Plant Power' Ltd.) was formed in 2003. Many of those who took the first initiative are included in the group of 17 farmers who own 20% of the company. The other co-owners are VafabMiljö, LRF (the national farmers' organisation) and Mälarenergi (Mälare Energy). In the same year, 'Plant Power' became a demonstration project for optimisation of biogas production from organic waste and crops within the EU project 'Agroptigas'. In autumn 2004, the upgrading plant started operating and sixteen of the city buses began running on biogas. Initially, only the biogas produced at the town sewage treatment plant was upgraded. In the summer of 2005, a new biogas plant opened for co-digestion of household wastes and silaged ley crops at Gryta waste treatment plant outside Västerås.

The 'Plant Power' project is unique in its way, considering the degree of local involvement and collaboration between the local authority, energy companies and farmers, the composition of the substrate and the many benefits accruing to the environment. Digesting ley crops to produce a bio-manure that can be spread on purely arable farms is one way to maintain crop production in otherwise marginal rural areas suffering from poor profitability. The biogas plant can be seen as a 'mechanical cow', replacing the work carried out by ruminants. The application of bio-manure improves the nitrogen status and structure of the soil, and there is no need to buy mineral fertilizer. This means that the farmers participating in the 'Plant Power' project are contributing to maintaining a thriving rural landscape.

The biogas plant and substrate

The biogas plant treats food wastes, silaged grass ley and sludge from grease separators in a one-step continuously-mixed mesophilic (37°C) digester with a volume of 4000 m³. The source-sorted household waste is collected in paper bags in ventilated containers. About 90% of the 144,000 households in the area participate. At the biogas plant, the waste is chopped up, mixed with water and pasteurized at 70°C for one hour, before it is fed into the reactor.

The farmers are contracted by the company to grow two or three-year leys on 300 ha of land, with a high proportion of clover to improve soil structure. The ley is harvested two or three times per year, in the same way as for normal large-scale silage production for cattle. At harvest, the crop is dried and chopped. It is then stored in air-tight plastic bags with a diameter of 3.5 m and a length of 80 to 90 m.

The silage is transported to the nearby biogas plant continuously during the year, and is fed into the reactor without any pre-treatment.



Figure 4.5.2 The silage is packed in plastic bags, Västerås

Upgrading and use of the biogas

Most of the biogas is upgraded to vehicle fuel. The remainder is used to produce electricity and heat. Upgrading takes place in a pressurized re-circulated water wash, with a capacity of 150 to 550 Nm³ per hour. At full capacity, the system is fed with slightly less than 1 m³ of fresh water per hour. The plant at Gryta produces biogas with an energy content of 15,000 MWh each year, equivalent to more than 1.6 million litres of petrol. The upgrading plant also receives biogas from the sewage treatment plant equivalent to 8000 MWh. The total amount of gas that can be used as vehicle fuel is therefore equivalent to 2.5 million litres of petrol.

Distribution of the biogas

The biogas is produced both at Kungsängens sewage treatment plant and at Gryta waste treatment plant, where the upgrading facility is also located. Pressurized raw gas from the sewage treatment plant is carried through an 8.5 km long pipeline to the upgrading facility at Gryta. The pipeline for the upgraded gas is laid, for the most part, in the same trench as the pipeline for the raw gas from the sewage treatment plant. Both pipelines are made of polyethylene and withstand a maximum pressure of 4 bars.

Another pipeline, which is c. 900 m long, takes the gas from Gryta that is not upgraded to a gas engine and boiler to produce electricity and heat. Optical cables

were buried in the same trenches as the gas pipelines for communication between the plants.

The upgraded biogas is pressurized at the bus depot in a compressor with a capacity of 400 Nm³ per hour. The gas is stored in a 32 m³ (wet volume) high pressure container that withstands a pressure of 350 bars. There is one station for quick re-filling of buses and refuse collection vehicles and another public filling station for cars. A store of liquid natural gas (capacity 21 tons, or 50 m³) guarantees a supply of fuel to the city buses.

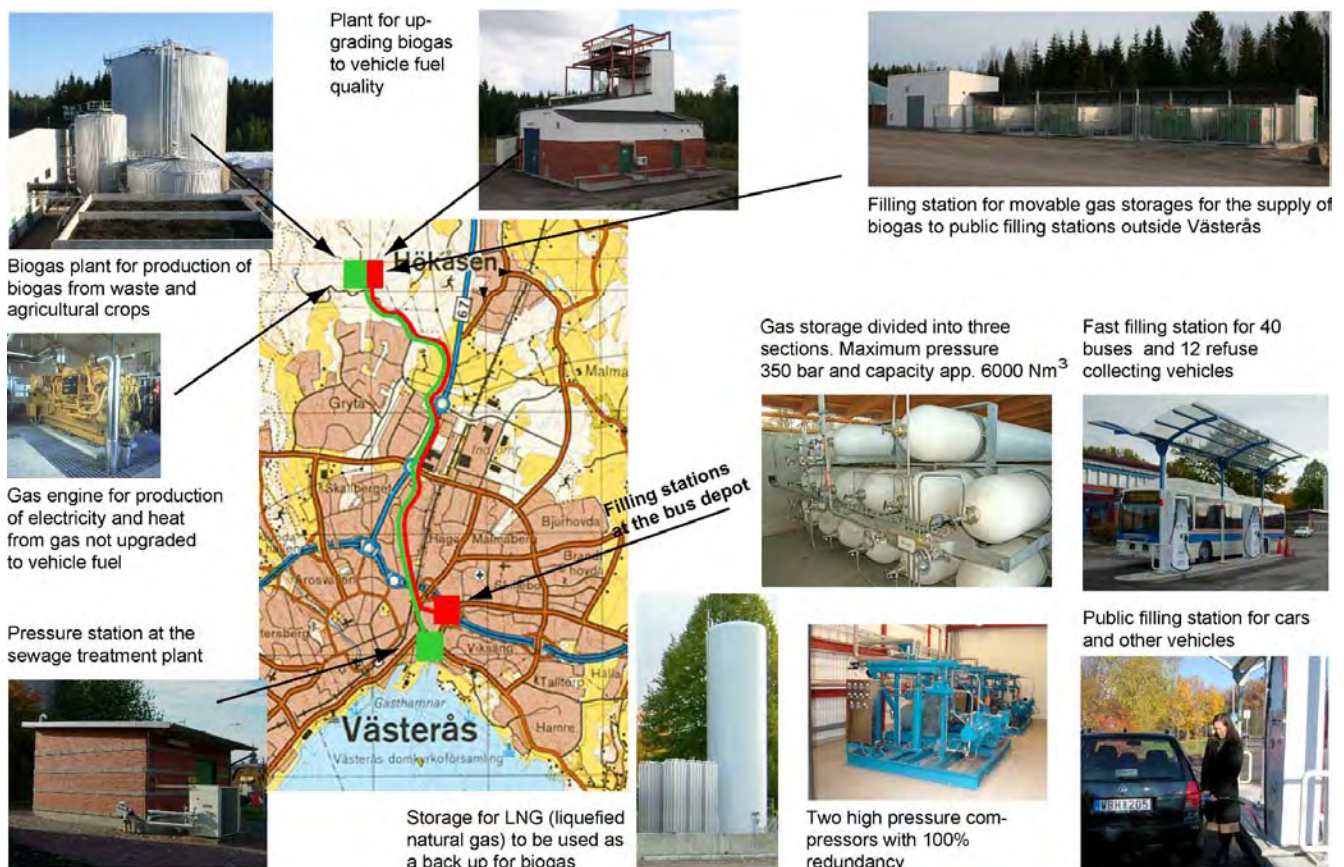

Figure 4.5.3 Schematic diagram of the system for gas distribution in Västerås

Bio-manure

The bio-manure is separated into solid and liquid phases. The solid bio-manure has a dry weight content of 25 to 30% and is handled as normal solid manure, with conventional solid manure spreaders. The liquid bio-manure, with a dry weight content of 2-3% is pumped and spread with conventional liquid manure spreaders. The division of the bio-manure into two phases also results in a partitioning of the plant nutrients and fibre content, so that the solid phase can be seen primarily as a phosphorous-rich soil conditioner, while the liquid phase is a nitrogen-rich fertilizer.

Financing

The project is financed by the share capital invested in the company by the owners, loans, investment support from the local investment program LIP, and support from the EU through the Agroptigas project. The development of biogas in Västerås has been an economically viable project.

Lessons learned

The construction of the plants went mostly according to plan and full production of biogas was achieved after the plant had been operating for c. one and a half years. At an early stage, the plant was complemented with an extra crusher and sieve for more effective pre-treatment of household waste. The technique of feeding the process with silage has taken some time to develop, but this has been working satisfactorily since 2008. One experience from the project is that all parties should be involved from the beginning and that legally binding contracts should be drawn up for the supply of raw materials and delivery of bio-manure.

Benefits for the environment and society

The 'Plant Power' project in Västerås is unique in its own way. The biogas plant is an important component of a complete system for re-cycling raw materials, waste, nutrients and energy between urban and rural areas. Farmers participate actively through their co-ownership of a company that links together the activities of the local authority with waste management and energy generating companies. The project has many winners, not least the farmers themselves who, after digestion, receive a high-quality fertilizer. This makes ecological farming economically favourable, even without access to animal manure.

To date, the project has resulted in energy savings in the form of fossil fuel equivalent to 2.5 million litres of petrol per year. The amount of organic waste incinerated has decreased by 14000 tons per year. The reduction in fossil carbon dioxide emissions has been calculated at 5500 tons per year. The bio-manure delivered from the plant returns c. 1000 tons of organic matter, 100 tons of nitrogen, 11 tons of phosphorous and 60 tons of potassium to arable land each year.

Facts 1. Basic data on the biogas plant

Start year (biogas production):	2005
Digester volume:	1 x 4 000 m ³
Process temperature:	37°C
Start year (upgrading):	2004
Upgrading method:	Water wash

Facts 2. Yearly inputs and outputs

Substrate:	
Source-sorted organic household waste	14 000 tons

Sludge from grease separators	2 000 tons
Silaged ley crops	5 000 tons
Biogas:	
From the biogas plant	15 000 MWh
From the sewage treatment plant	8 000 MWh
Upgraded biogas	23 000 MWh
Bio-manure:	
Solid bio-manure	3 500 tons
Liquid bio-manure	13 000 tons

Contacts

Svensk Växtkraft AB (www.vafabmiljo.se):	Per-Erik Persson, Managing Director Telephone: +46 21 39 35 65 E-mail: per-erik.persson@vafabmiljo.se Carl-Magnus Pettersson, Plant Manager Telephone: +46 70 465 35 33 E-mail: carl-magnus.pettersson@vafabmiljo.se
Agroptigas:	Sarah Nilsson, Project Manager Telephone: +46 470 415 93 E-mail: sarah.nilsson@kommun.vaxjo.se

Suppliers

Biogas plant:	Ros Roca International AS www.rosroca.de
Upgrading plant and filling station:	YIT Vatten och miljöteknik www.yit.fi
Gas pipelines and storage tanks:	Lindesberg Grus och Maskin Telephone: +46 581 176 75

Sewage treatment plants

Biogas has been produced at sewage treatment plants in Sweden since the 1940's. The original reason was to reduce the amount of sludge produced during water treatment. However, the energy crises in the 1970's stimulated growing interest in making better use of the energy contained in the sludge. This led to further research and development work and an expansion of the biogas process at sewage treatment plants.

There are c. 2000 sewage treatment plants in Sweden, but biogas is only produced at c. 140. This is because it is not profitable to produce biogas at the smaller sewage treatment plants.

There are several steps in the water treatment process. The wastewater is first led to an aerated basin where aerobic microorganisms decompose the organic material. The resulting sludge is then treated anaerobically in a digester. Mesophilic digestion dominates at sewage plants (i.e. process temperatures are around 35°C). The commonest type of digester design is a continuously-mixed one-step process with continuous feeding of substrate.

The biogas is traditionally used to heat buildings or is 'flared off'. However, in recent years, there has been a growing interest at several sewage treatment plants in Sweden in upgrading the biogas to vehicle fuel quality.

This handbook describes the biogas plant at Ryaverket in Gothenburg and two biogas plants in Stockholm (Bromma and Henriksdal).

Experiences from sewage treatment plants

An increasing number of sewage treatment plants are becoming interested in upgrading their biogas to vehicle fuel as a consequence of the increasing demand for biogas as an environmentally-friendly alternative to fossil fuels. The experience from Gothenburg and Stockholm shows that such developments are, in the long-term, both advantageous for the environment and profitable.

In general, there is an unexploited capacity for increased biogas production at sewage treatment plants in Sweden. In many cases, more biogas per reactor volume can be produced by optimising process conditions. In addition, many local authorities are planning to increase biogas production by co-digesting sewage sludge with, for example, source-sorted food wastes or organic wastes from the food industry.

The quality of the sludge residue is determined by the degree of contamination of the substrate. If the wastewater contains contaminants (e.g. heavy metals, residues of medicines or pesticides), then there is a risk that these will be found in the residue, which will restrict its use. The project 'Pure nutrients from wastewater' (Revaq) started in 2003 as a collaborative project between several partner organisations with the objective to improve the quality of the sludge residue produced by sewage treatment plants in Sweden. Amongst other partners, c.10 treatment plants were involved in this project. Revaq's goal was to produce sludge that can be spread on arable land without compromising existing environmental objectives. The project finished in 2007, but this initiative has led to an improved environmental awareness at sewage treatment plants and a desire to continue with these efforts.

Long-term efforts to improve the quality of sludge residues require a broad consensus among public authorities and branch organisations and close collaboration between them. It seems likely that tougher regulations will be introduced in the future concerning the recycling of metals and organic substances, which may encourage the spreading of sludge residues from wastewater treatment plants on agricultural land.

The biogas plant in Gothenburg

Facts/unique: Upgrading with the Coaab technique and distribution to the gas grid. The upgrading plant is one of the largest in the world.



Figure 4.6.1 The upgrading plant at Arendal, Gothenburg

The wastewater treatment plant at Gryaab has been digesting waste water sludge anaerobically since 1990. The two reactors were built to handle the sludge produced from the treatment of wastewater at the Rya plant in Gothenburg. The biogas was originally used to generate electricity and heat. Later, the biogas was distributed through the Gothenburg gas grid. On the initiative of the foundation 'Svensk Metanteknik' (Swedish methane technology), a small upgrading plant was built at Rya in 1992 to convert some of the biogas to vehicle fuel quality. The development of biogas purification technology continued at Gryaab, and in 1994 the first biogas filling station in Sweden for private cars was opened at the plant. Starting in 1996, fatty wastes destined for the reactor at Gryaab could be handled separately. The energy company 'Göteborg Energi' (Gothenburg Energy) soon noted an increased demand in the region for environmentally-friendly vehicle fuels, and decided to increase the capacity to upgrade biogas. In 2007, a new upgrading plant owned by Göteborg Energi was opened in Arendal, which purifies the gas by chemical absorption.

Although it was a small-scale operation, the Rya plant was, together with Linköping, the first in the country to purify biogas from sludge. The facility to handle fatty wastes was also one of the first of its kind. The new upgrading plant in Arendal is one of the largest in the world. Göteborg Energi is aiming to replace all the natural gas used in Gothenburg with biogas and is continuing to invest resources in projects that promote biogas production in the region. For example, there are plans to produce bio-methane from combustion of biomass waste from the forest industry (e.g. branches, twigs etc. remaining after felling).

The biogas plant and substrate

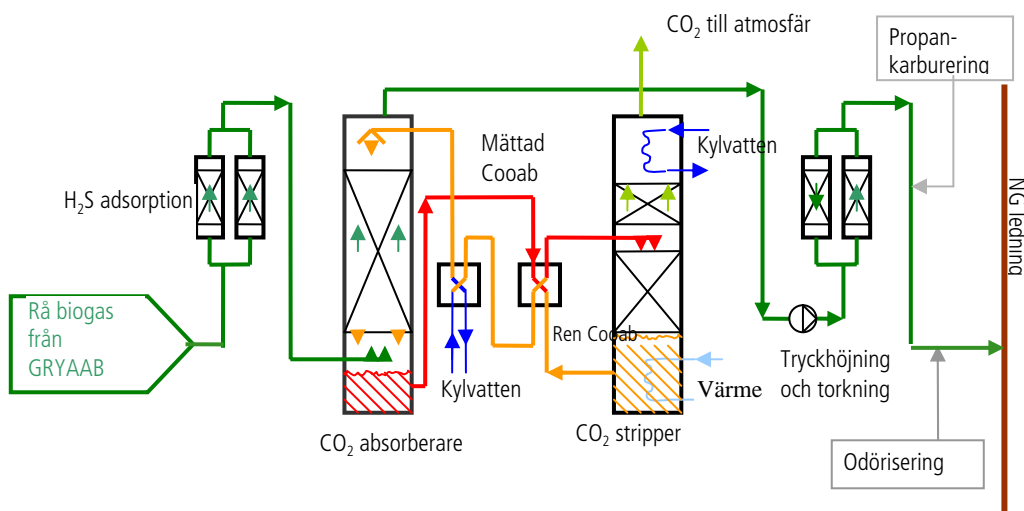

Figure 4.6.2 Diagram of the upgrading process with Coaab

The Gryaab plant treats c. 430,000 m³ per year of thickened raw sludge from the wastewater treatment plant at Rya, equivalent to 21,000 tons dry weight. There are

two mesophilic (37°C) one-step (continuously-mixed) anaerobic digesters, each with a volume of 11,400 m³. The retention time for the material is c. 20 days. In 1996, the reactors also started to treat sludge from grease separators and other organic substrates such as ground food wastes from restaurants and schools in the Gothenburg region, which has increased the production of biogas. The fatty wastes are received in a separate closed system, from where the organic material is pumped directly into the reactor without mixing with the other substrates.

Upgrading and use of the biogas

Gryaab biogas plant produces each year c. 60,000 MWh of raw gas. This is sold to Göteborg Energi, and most is then upgraded to natural gas quality. There is also a smaller upgrading plant at Gryaab that has been operating since 1992 using PSA-technology. Only 0.2% of the biogas production is upgraded to run cars owned by the treatment plant.

Upgrading capacity increased significantly in 2007 when the new plant started operations. At this facility, chemical absorption is used to separate carbon dioxide from methane. A solvent (Cooab) is added, which effectively absorbs carbon dioxide. The Cooab solution is then regenerated in the process. The upgrading plants at Gothenburg and Borås are the only ones in Sweden that use this technology. The capacity of the new upgrading plant is 1,600 Nm³ per hour, which makes it one of the largest in the world. Roughly 60,000 MWh of purified gas is produced each year, equivalent to c. 6 million litres of petrol. Methane leakage from the plant is very small (less than 0.1%).

Distribution of the biogas

The biogas produced at Gryaab is transported in a c. 3 km long pipeline to the new upgrading facility at Arendal. The purified biogas is distributed through the gas grid after adding a small amount of propane to achieve the same energy content as natural gas. 'Fordonsgas Sverige' (Vehicle Gas Sweden) buys the upgraded gas from Göteborg Energi for distribution to their customers. There are today (March 2008) eleven public filling stations for biogas in the Gothenburg area.

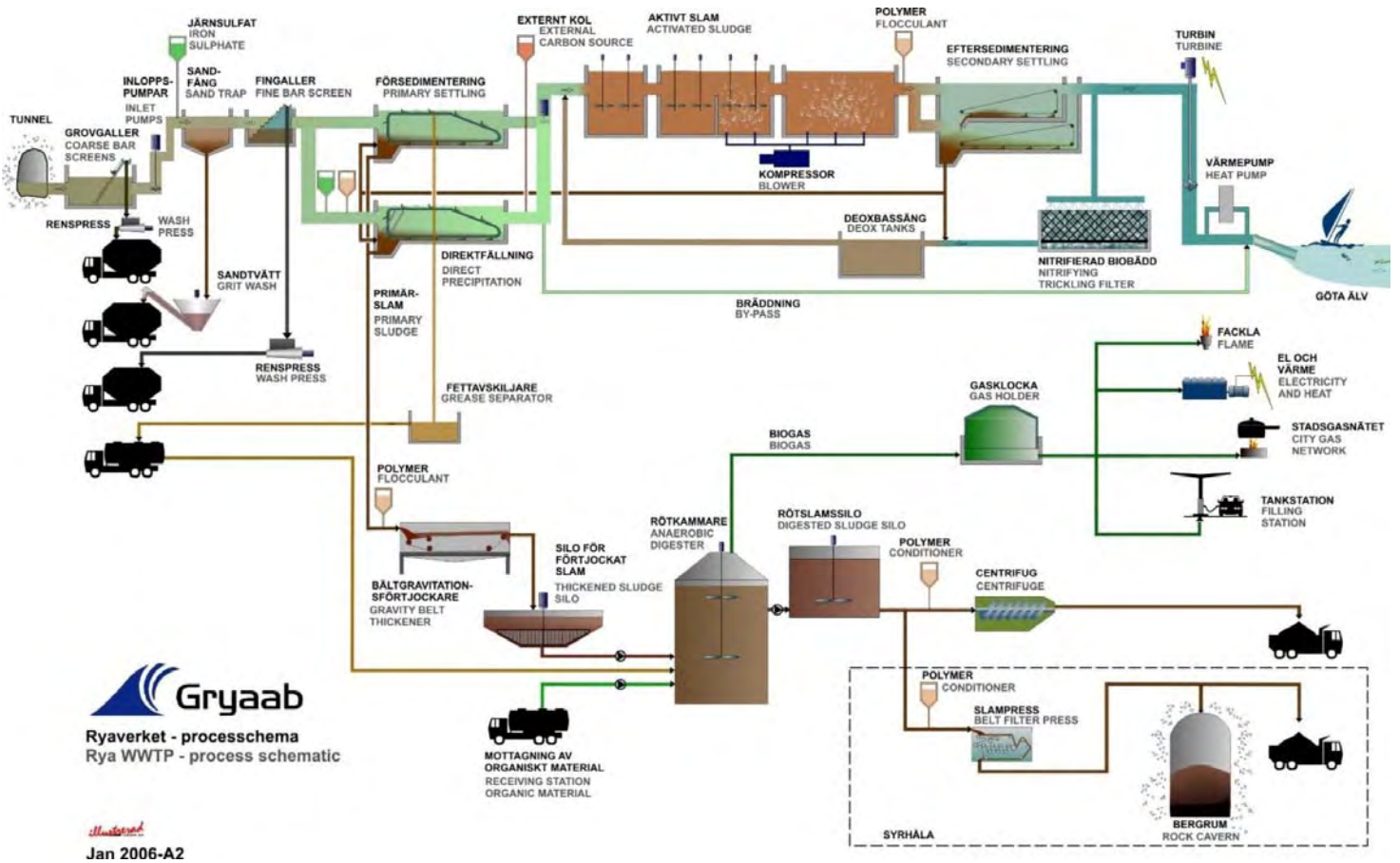

Figure 4.6.3 Diagram of the biogas plant in Gothenburg

Digestion residue

The 50,000 tons of digested sludge produced annually at the biogas plant is composted. Trucks deliver sludge from the Rya plant to the composting facility 6 or 7 times daily. The sludge is first mixed with sawdust or bark. Rock flour and sand is also added after composting, and the final product is marketed as a soil material for construction. Of the order of 194,000 tons of soil material is produced annually for construction of golf courses and roads etc. and as a cover material in landfills. Gryaab is also working towards the goal of returning some of the sludge to agricultural land.

Financing

The reactors cost 88 million SEK (in 1990). The project was self-financed. The investment costs for the new upgrading plant were 40 million SEK, 9 million SEK of which were covered by a grant from KLIMP. In 1998, Gryaab received a 0.6 million SEK grant from LIP to develop facilities to co-digest sewage sludge with sludge from grease separators and food wastes. The total cost of this investment was 5 million SEK. Other LIP and KLIMP grants have been received, for example, to construct new filling stations. The new upgrading plant will be profitable in the long-term.

Lessons learned

The construction of the reactors went according to plan, and resulted in a significant profit due to reduced costs for sludge disposal. The separate handling of fatty wastes is working well and has decreased the amount of fat transported through the sewage pipe network. The construction of the new upgrading plant has also gone according to plan, although it was delayed a little. A plant that treats combustible gas is covered by many regulations, something which is worth considering for those who are planning similar projects. The purification technique is working quite well, but the plant has suffered some initial technical problems that the operators hope to fix. The plant received a lot of attention during construction. The interest in biogas has increased dramatically since the project started, and the plant has received many visits from both politicians and overseas visitors.

It is important to ensure that the whole chain of production works satisfactorily, from the supply of raw materials to the distribution of the final product. Careful analyses should be carried out of the available raw materials, how much gas can be produced, the size of the market for the final products, and how the biogas will be distributed to the customer. Several different upgrading techniques are available, each with its advantages and disadvantages. The best technique to adopt will depend on the situation and conditions at the plant in question.

Benefits for the environment and society

The environment has benefited from the fact that the large amounts of biogas produced at Gryaab are now converted to vehicle fuel quality. The development of the upgrading plant has decreased emissions of fossil carbon dioxide by nearly 12,000 tons annually. Furthermore, the air quality in the city is improving as more cars are driven on biogas. The demand for biogas as a vehicle fuel is continuously increasing and more filling stations are opening, which improves its availability. The existing natural gas grid in Gothenburg has played an important role in this growth, since the biogas can be distributed together with the natural gas without the need for new pipelines.

The Gryaab plant makes neither a profit nor a loss on the increased biogas production and its sale for upgrading, but it does help to maintain the costs of waste water treatment that are charged to householders at a low level. The amount of sludge resulting from wastewater treatment has decreased considerably since the reactors were installed. The sludge supplied to the following compost process smells much less than when undigested sludge is composted.

Facts 1. Basic data on the biogas plant

Start year (biogas production):	1990
Digester volume:	2 x 11 400 m ³
Process temperature:	37°C
Start year (upgrading):	1992 and 2007
Upgrading method:	PSA and Coaab
Investment costs (reactor):	88 million SEK (1990)
Investment costs (upgrading):	40 million SEK (2007)

Facts 2. Yearly inputs and outputs

Substrate:	
Sludge from grease separators	5 000 tons (c. 250 tons dry weight)
Other organic waste	4 000 tons (c. 200 tons dry weight)
Thickened sludge (wastewater treatment)	430 000 tons (21 000 tons dry weight)
Biogas:	
From the biogas plant	60 000 MWh
Upgraded biogas	60 000 MWh
Digestion residue:	
De-watered sludge	50 000 tons
Soil products	194 000 tons

Contacts

	<p>www.goteborgenergi.se www.gryaab.se</p> <p>Ola Fredriksson, Gryaab Telephone: +46 31 647400 E-mail: ola.fredriksson@gryaab.se</p> <p>Emma Jacobsson, Göteborg Energi AB Telephone: +46 31 62 73 12 E-mail: emma.jacobsson@goteborgenergi.se</p>
--	--

Suppliers

Biogas plant:	Plant: Läckeby Water AB www.lackebywater.se
	Construction: NCC www.ncc.se
Upgrading plant, Main contractor:	Läckeby Water AB

	www.lackebywater.se/sv
Upgrading plant, Sub-contractors:	Electricity and instrumentation: Actemium Stenungsund c/o Emil Lundgren AB www.emillundgren.se/stenungsund Construction: Tuve Bygg AB www.tuvebygg.se

The biogas plants in Stockholm city

Facts/unique: Ambitious development plans to increase biogas production and distribution. Upgrading of biogas at one of the world's largest underground sewage treatment plants.



Figure 4.7.1 Biogas bus in Stockholm

Two sewage treatment plants in Stockholm, Bromma and Henriksdal, upgrade the biogas they produce to vehicle fuel quality. Both plants are briefly described below.

Bromma (earlier Åkeshov/Nockeby) was the first sewage treatment plant in Stockholm. It opened in 1934, and since then the plant has been extended and

improved in several stages. The plant now has 42 purification basins, and the average inflow of wastewater to the plant is 130,000 m³ per day. The treatment process includes chemical purification by precipitation with iron sulphate, sedimentation, aeration, anaerobic digestion, nitrogen removal and filtration. Anaerobic digestion takes place at the plant in Åkeshov, while the aeration basins are located at Nockeby. From Åkeshov, the water flows under gravity c.600 m to the Nockeby plant for further treatment.

The facility at Henriksdal is one of the world's largest underground sewage treatment plants. The first nine purification basins were constructed in 1941, and a further 25 were built in the years up to 1971. After several purification steps, including sedimentation and aeration, the clean water is discharged into the lake Saltsjön. The plant at Henriksdal treats up to 370,000 m³ of wastewater per day.

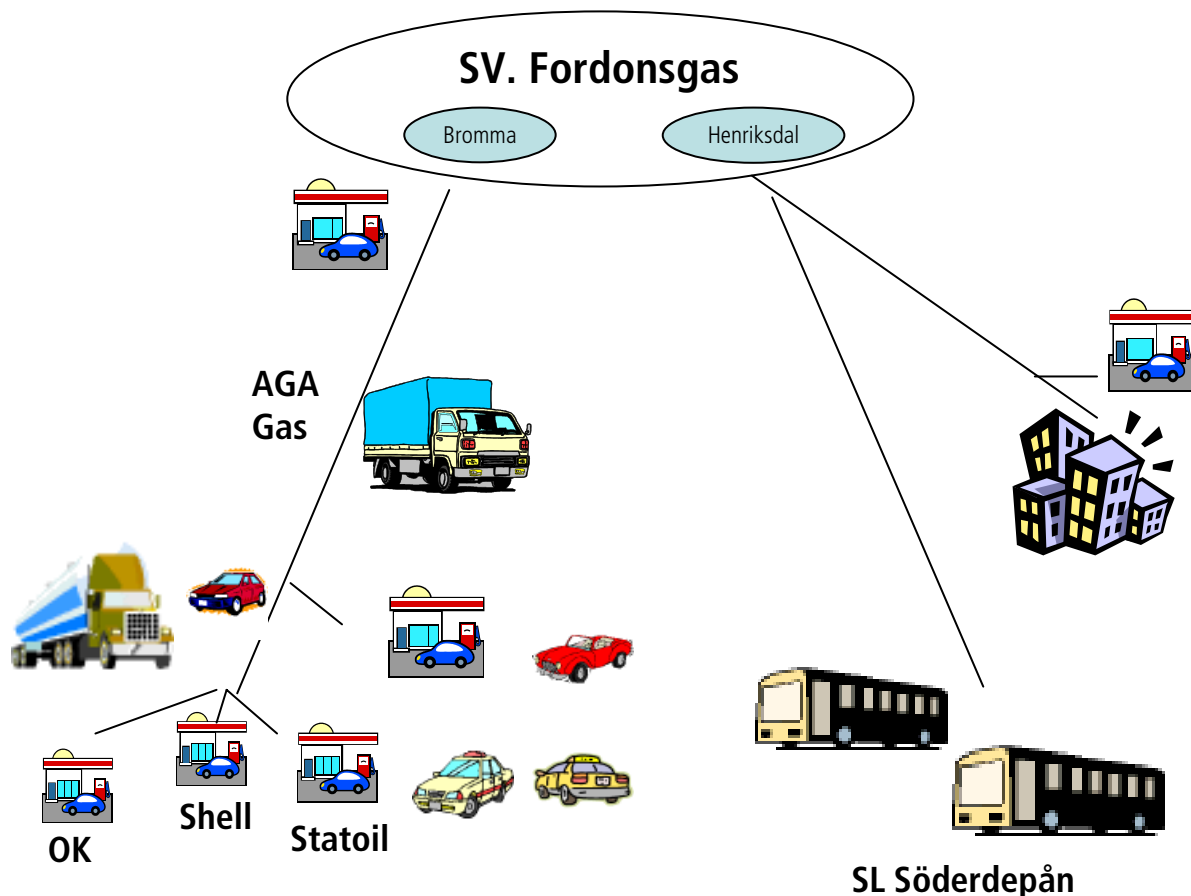

Figure 4.7.2 Distribution of the biogas from the plants in Bromma and Henriksdal.

The local authority in Stockholm and Stockholm Vatten (Stockholm Water), who run the treatment plants, have long had the goal of increasing the use of biogas as a vehicle fuel. One example is the project 'Environmental cars' in Stockholm, which distributes EU grants to companies and organisations that invest in biogas vehicles. A pilot-scale upgrading plant started operating in Bromma as early as 1996. Large-

scale upgrading started in 2000, and an upgrading plant began operating at Henriksdal in 2003. A number of biogas filling stations have opened and more and more biogas cars are being bought. The demand for biogas is therefore greater than the supply, so that plans are underway to further increase the production and availability of biogas in the greater Stockholm area. This is a collaborative effort involving Stockholm Water, the city of Stockholm, Stockholm Gas AB, Aga Gas and Greater Stockholms Lokaltrafik (SL, the public transportation company in Stockholm).

The biogas plant and substrate

Only sewage sludge is digested at Bromma. Anaerobic digestion takes place in six reactors with a total volume of 12,000 m³. The processes are one-step and continuously-mixed, with a temperature of 35 to 37°C and a retention time of 20 days. A new reactor 6,000 m³ in size, is being built (2008).

The first reactors at Henriksdal were built during the 1940's. Sewage sludge is the main substrate, with 600,000 tons digested every year. Apart from sludge from the sewage treatment plant, the substrate consists of organic material in the form of fats from the city's 2,000 grease separators (c. 25,000 tons per year) and smaller amounts of food wastes from restaurants and shops (c. 2,000 tons per year). In total, the substrate comprises 80-85% sludge, 15-20% fats and 1-2% food wastes. The imported substrate is mixed with the sludge and digested in seven reactors with a total volume of 39,000 m³. The process is one-step, continuously-mixed and mesophilic (35 to 37°C), with a retention time of c. 19 days.

New production

Stockholm Gas AB, a subsidiary company wholly owned by Fortum Värme, is planning a new production plant for biogas. The plant will produce c. 100,000 MWh of upgraded biogas per year from crops and the waste products of the agricultural and food industries. The intention is to locate the plant next to the Sofielund landfill in Huddinge.

The new liquid natural gas (LNG) plant that will replace the town gasworks at Värtan will be located next to the biogas plant. Town gas has been produced from naphtha (light petrol) at Värtan since 1971. The gasworks will be decommissioned from 2010 to make way for new offices and homes. The gas from the new plants in Huddinge will be distributed to Stockholm in a new pipeline to Hammarby.

Upgrading and use of the biogas

Nowadays, most of the biogas produced at Bromma and Henriksdal is upgraded to vehicle fuel quality. Previously, the biogas was used to heat plant buildings and, at Henriksdal, to generate electricity. Both Bromma and Henriksdal are now heated through the district heating network. The upgrading plant at Bromma uses the PSA

technique and can purify c. 30,000 MWh of biogas per year. The upgrading plant at Henriksdal uses the water wash method and can purify up to c. 69,000 MWh of biogas annually. Together, the plants currently produce c.55,000 MWh of upgraded biogas per year. A small amount of the upgraded gas (c.2%) is used in household gas ovens in Hammarby sjöstad (a Stockholm suburb), while the remainder is used as vehicle fuel. The upgraded biogas produced at Bromma and Henriksdal replaces c. 60 million litres of petrol per year. There are also plans to run city ferries on biogas.

The production of biogas is expected to increase at both Bromma and Henriksdal as a result of optimisation of the processes and selection of new substrate mixtures (i.e. more food waste). Sewage treatment plants at Lidingö (Käppala) and Södertälje (Himmerfjärden in Grödinge) are also planning to increase biogas production, as well as begin upgrading to vehicle fuel quality.

Distribution of the biogas

Some of the biogas produced at Bromma is distributed through a pipeline to the Shell filling station located at the entrance to the Åkeshov plant, and some by container transport (Aga) to public filling stations in the Stockholm area. Upgraded gas from Henriksdal is transported in a c. 2 km long pipe under a pressure of 4 bars to SL's bus depot at Söderhallarna, where it is compressed to 350 bars and used to run biogas buses. Today, SL has 50 biogas buses, but intends to increase this number in the future. Biogas from Henriksdal will then support 140 of SL's buses. Another pipeline transports gas to Fortum, who supply gas to ovens in 1,000 apartments in Hammarby sjöstad. A biogas filling station is also located in the area.

Aga Gas also collects biogas from Henriksdal to deliver to public gas filling stations. Aga Gas collect on average 5 loads of upgraded biogas in containers from Bromma and Henriksdal daily, equivalent to half of the daily demand in the Stockholm region. Aga Gas build and manage the compressor stations for biogas and are continually increasing the number of filling stations in the greater Stockholm area, in collaboration with Shell, Statoil, OK/Q8, among others. There are today (March 2008) 11 gas filling stations in the Stockholm area.

Stockholm Gas is planning to build a new pipeline network to distribute vehicle gas (mainly biogas), making use of disused sections of the 800 km long town gas network. The network will be constructed in stages, depending on demand, and the first sections are expected to be operational in 2009. In the long run, the network should link several of SL's bus depots and filling stations with the city's sewage treatment plants.



Figure 4.7.3 Map of existing (green dots) and planned (red dots) filling stations in Stockholm (March 2008).

Aga Gas has built a depot for LNG in Knivsta. The depot acts as a reserve in case the biogas runs out. The gas is distributed to filling stations in containers. Aga Gas is also planning to establish an LNG plant in Nynäshamn together with Nynäs Refinery.

Digestion residue

The residues from digesting the various substrates (sludge, food wastes, fats) at Henriksdal are de-watered together. The de-watered digestion residue is used as a soil material to remediate mine wastes at the Aitik mine near Gällivare. Plants are able to establish themselves in the mine waste areas by utilizing the nutrients in the digestion residues. De-watered sludge from Bromma is mixed with ash and used as a cover material at the disused landfill at Lövsta. Roughly 75,000 tons of de-watered sludge is produced annually at Stockholm Water's plants.

Financing

The total investment cost for the upgrading facilities at Bromma and Henriksdal was 134 million SEK. This was mostly self-financed, although a grant worth 27 million SEK was received from LIP in 1998. Together with the city of Stockholm, Fortum Värme received a KLIMP grant in 2007 to build the new biogas plant for

digestion of agricultural crops. In the short term, the income generated will just about cover these investments costs. In the longer-term, they are expected to become profitable.

Lessons learned

The extensions to the upgrading plants were completed according to schedule, but the cost was greater than budgeted for. One reason may be that the upgrading technique is relatively new and untested. Up to now, the distribution system for gas in Stockholm has been inadequate, and there are too few filling stations. It is very important that the entire biogas system works satisfactorily, from production through to distribution and marketing. Planning is made difficult by some key factors which are uncertain and continually changing, for example taxes, prices and market conditions.

Benefits for the environment and society

The efforts at Henriksdal and Bromma waste treatment plants to develop biogas as a vehicle fuel have led to the establishment of a market for biogas in greater Stockholm. Interest is increasing in the Stockholm region in the use of biogas as an environmentally-friendly vehicle fuel. As a result of these recent developments, emissions of fossil carbon dioxide have so far decreased by c.14,000 tons per year. Biogas cars are exempt from the Stockholm traffic congestion toll charges. The more biogas replaces petrol-driven cars, the cleaner the city centre air in Stockholm will become. This has long been the objective of both the municipality of Stockholm and Stockholm Water, and there is now a political will to develop biogas in the city of Stockholm. The great interest in biogas cars has led to a situation in which fuel supplies sometimes run out. However, the efforts being made to increase production and improve the 'back-up' should resolve these problems and finally establish biogas on the market in Stockholm. This will benefit the environment in the coming years.

Facts 1. Basic data on the Bromma plant

Start year (digestion):	1934
Digester volume:	7 reactors, total volume 18000 m ³
Process temperature:	35-37°C
Start year (upgrading):	1996, 2000
Upgrading method:	PSA
Investment costs (upgrading):	35 million SEK

Facts 1. Basic data on the Henriksdal plant

Start year (digestion):	1941
Digester volume:	7 reactors, total volume 39000 m ³
Process temperature:	35-37°C
Start year (upgrading):	2003

Upgrading method:	Water wash
Investment costs (upgrading):	99 million SEK

Facts 2. yearly inputs and outputs, Bromma

Substrate:	
Sewage sludge	12000 tons dry weight
Biogas:	
From the biogas plant	21 000 MWh
Upgraded biogas	19 000 MWh
Digestion residue:	
De-watered sludge	19 700 tons (31.6% dry weight)

Facts 2. Yearly inputs and outputs, Henriksdal

Substrate:	
Sewage sludge	27 000 tons dry weight
Source-sorted food waste	2 000 tons
Fats	c. 25 000 tons
Biogas:	
From the biogas plant	65 000 MWh
Upgraded biogas	58 000 MWh (maximum)
Digestion residue:	
De-watered sludge	56 500 tons (27,5 % dry weight)

Contacts

<p>www.stockholmvatten.se www.aga.se/biogas www.stockholmgas.se www.fortum.se</p> <p>Marta Tendaj, Stockholm Vatten Telephone: +46 8 522 120 28 E-mail: marta.tendaj@stockholmvatten.se</p> <p>Roger Andersson, Aga Gas AB Telephone: +46 8 706 95 00 E-mail: roger.andersson@se.aga.com</p> <p>Per-Olof Moberg, Stockholm Gas AB Telephone: +46 8 671 75 12</p>
--

	E-mail: per-olof.moberg@fortum.com
--	------------------------------------

Suppliers	
Upgrading plant, pipes, gas pipes, filling stations	<p>Läckeby Water www.lackebywater.se</p> <p>Malmberg www.malmberg.se</p> <p>Carbotech www.carbotech.com</p>

Farm-based biogas plants

There is great interest in Sweden in farm-based anaerobic digesters. Eight such biogas plants are in operation today, but more are planned. Of these existing plants, three are located at high schools and agricultural colleges (Lövsta on the island of Gotland, Plönninge in Halland and Ökna in Södermanland), where they are also used for teaching purposes. A number of smaller farm-scale plants were built in Sweden in the 1970's and 1980's, but very few of them are still operating today.

The processes are normally small-scale, with reactor volumes between 100 and 500 m³, but some are larger (e.g. the plants at Alvik and Bjuv). Most farm-based plants are mesophilic with process temperatures between 35 and 37°C. The digesters at Alvik and Ökna are thermophilic digesters (50-53°C). The substrates used in farm-scale digesters vary. All of them digest manure, but other raw materials are also used, for example ley crops, food wastes, vegetables, sugar beet tops and slaughterhouse waste.

The biogas is normally used to heat the farm buildings. There is little need for heating during warm periods of the year, but gas production is reasonably constant. Some plants exploit the possibility to generate electricity from the biogas, which is used locally on the farm or sold via the electricity grid.

There is growing interest in the production of vehicle fuel at farm-based biogas plants. In 2004, the agricultural school at Ökna in Nynäs was the first to build an

on-farm upgrading plant to purify biogas. The plant design is a modified water wash with a closed water system. The biogas is used to run the school vehicles, including several tractors that have been converted to gas. The plant at Bjuv also produces vehicle gas.

Three farm-based biogas plants located in Norrbotten (Alviksgården) and Skåne (Bjuv and Hagavik) are briefly described in this handbook.

Experiences from farm-based biogas plants

On-farm anaerobic digestion of manure, crops and food wastes etc. can be carried out with relatively simple technology, making use of existing storage facilities and spreader equipment etc. Farmers have extensive experience of crop production and manure handling, which helps in the planning and operation of the plant.

One important reason why farmers are interested in producing biogas is that the process also results in a bio-manure with many favourable properties. Compared with fresh manure, digestion allows the farmer to achieve better control over the nitrogen content of the final product, which enables improved precision in fertilization, as well as reducing emissions of methane, ammonia and nitrous oxide. There is also less need to buy mineral fertilizers. Liquid bio-manure smells less than fresh manure and generally flows more easily, which makes it easy to spread with existing equipment.

It is also significant that farmers that produce power and heat from biogas are also entitled to electricity certificates. However, to date, electricity prices in Sweden have not favoured electricity generation from biogas to any great extent. It is often more profitable to use the power and heat generated from biogas internally within the company. If necessary, the electricity can also be distributed to the grid. Thus, the economic obstacles hampering the development of on-farm biogas are often balanced by the perceived environmental benefits combined with the attraction of becoming self-sufficient in electricity and heat.

Several cooperative projects on the construction of upgrading plants to purify biogas to vehicle fuel quality are in the planning stages. This requires cooperation between farmers within a region and the construction of pipeline networks for both the raw and upgraded gas. This results in economies of scale and should also reduce the investment costs related to the construction of pipelines and plant for gas production and purification.

The development of farm-based biogas in Sweden has to date been limited, largely because of uncertainties concerning profitability. Although there is a great deal of interest in the digestion of manure, crops etc., the construction of a biogas plant is a relatively large investment, which means that many farmers are adopting a 'wait

and see' attitude. However, this situation could change quickly, if energy becomes more expensive, and as local authorities and central government become increasingly aware of the advantages of biogas. It could then be worthwhile for individual farmers to invest in biogas.

New technological developments are needed to enable farm-based biogas production from manure, crops and crop residues. There is also a clear need for new cost-effective technologies for small-scale plants to upgrade biogas to vehicle fuel quality. The economics of farm-scale biogas production could be improved by simple, ready-to-install plant modules. Co-ordination among advisory and training services is needed to give better support in the whole process from initial planning to the final construction of the biogas plant.

The biogas plant at Alviksgården

Facts/unique: The first large-scale farm-based biogas plant in Sweden. Self-sufficient in heating and electricity.



Figure 4.8.1 Photograph of the biogas plant in Alvik

Alviksgården is a livestock farm located in the north of Sweden, near Luleå, with 16,000 pigs. The farm has 15 employees and its own slaughterhouse. Most of the feed is grown on the farm. The farm previously paid a company to take care of the slaughterhouse waste, but this was expensive. Therefore, the owner of Alviksgården, Mikael Hugoson, decided in the late 1990's to build a biogas plant to

treat both the pig manure and the waste from the slaughterhouse. The plant started operations in 2000.

Alviksgården is a self-sufficient farm. The 200 hectares surrounding the farm buildings produce feed for the pigs. The pigs are slaughtered on site and both the manure and the slaughterhouse waste are treated at the farm's biogas plant. The biogas supplies the farm buildings with heat and electricity. An electricity surplus is generated, the sale of which gives extra income to the company. The investment made in the biogas plant will be re-paid within 10 years. Alviksgården is an excellent example of how farm-scale biogas plants can be profitable and also benefit the environment.

The biogas plant and substrate

The plant consists of two reactors with a total volume of 2,300 m³. They digest 50 tons of pig manure and c. 50 tons of slaughterhouse waste each day, some of which comes from the farm, and the rest from slaughterhouses in Skellefteå and Ullånger. The manure is pumped directly from the pig sheds into the reactors, while the slaughterhouse waste is first ground in a mill before it is mixed with the manure in the reactor. The reactor is a one-step, continuously-mixed, thermophilic (50°C) process.



Figure 4.8.2 Process diagram of the biogas plant in Alvik

Distribution of the biogas

The plant produces c. 9,600 MWh of biogas per year. The gas is purified by removing sulphur and water vapour. The warm water is stored in a 60 m³ accumulator tank which supplies the entire farm with hot water. Electricity is generated from the remaining energy in the biogas using a 16 cylinder 35 litre gas

engine which produces 4,300 MWh every year. The electricity is sold to Luleå Energi (Luleå Energy), but c. 60% is 'bought back' and used on the farm.



Figure 4.8.3 A 16 cylinder 35 litre gas engine used to produce electricity in Alvik

Bio-manure

In total, c. 18,000 tons of bio-manure is produced each year, which has a dry weight content of 3-4%. This is stored in several tanks before being applied on nearby land using a liquid manure spreader. Alviksgården grows cereals on 200 hectares.

Financing

The biogas plant cost c. 20 million SEK to build. It was mostly self-financed, but 30% of the cost was covered by grants. The investment is expected to be paid off within 10 years. The difference in price between the electricity bought and sold from the farm is 0.25 SEK per kWh, which is equivalent to the cost of the electricity certificate. The profit is even larger due to the fact that there are no longer any costs for transporting and landfilling waste.

Lessons learned

A few initial teething problems were experienced, but the plant is now operating as planned. The bio-manure produced at the plant is of high quality, not least because the nitrogen is more easily available for the crops than is the case for the fresh undigested manure. In the planning stages, it is very important to make sure that an even and stable supply of substrate can be guaranteed, to prevent interruptions in operations. The process is checked on a daily basis. An automatic surveillance system is also linked to the plant.

Benefits for the environment and society

Alviksgården is self-sufficient. The pigs are born, grow and die on the farm, and their feed is produced on the farm's own land. Construction of the biogas plant has produced many benefits for the business and for the environment. The need for transport to and from the farm has been minimised. The costs of handling and

transporting the slaughterhouse waste have decreased, a practically odour-free bio-manure provides nutrients to the soil, and the farm is now self-sufficient in energy. Apart from the electricity generated, the plant also produces enough hot water to replace an equivalent consumption of c. 150 m³ of oil each year.

Facts 1. Basic data on the biogas plant

Start year (biogas production):	2000
Digester volume:	1 000 and 1 300 m ³
Process temperature:	50 °C
Investment costs:	20 million SEK

Facts 2. Yearly inputs and outputs

Substrate:	
Pig manure	16 000 tons
Slaughterhouse waste	1 800 tons
Biogas:	
From the biogas plant	9 600 MWh
To electricity generation	4 300 MWh
To heating	5 300 MWh
Bio-manure:	
Bio-manure	18 000 tons

Contacts

	www.konsumnorrboten.se/alviksgrisen Mikael Hugoson Telephone: +46 70 62 80 260 E-mail: mikael.hugoson@hugosons.se Mikael Lång Telephone: +46 70 62 80 436 E-mail: Mikael.lang@swipnet.se
--	---

Suppliers

Biogas plant:	Dansk Biogas www.danskbiogas.dk Electricity generation: Deutz www.deutz.com
---------------	---

The biogas plant in Bjuv

Facts/unique: Upgrading biogas on a large-scale with distribution to the gas grid.
Bio-manure is spread by a self-propelled hose spreader.



Figure 4.9.1 The Wråms Gunnarstorp castle in Bjuv

The estate of Wråms Gunnarstorp, located near Bjuv in Skåne, is run by a family-owned company. The owner, Rudolf Tornerhjelm, first had the idea of building a biogas plant in the early 2000's, prompted in part by a study trip to Denmark where he saw the advantages of the technology. The estate raises 6000 pigs for slaughter each year and the manure that is produced is very well suited to the biogas process. The biogas plant was ready by November 2006. Three owners have together formed the company 'Söderåsens Bioenergi AB' to run the plant: the family-owned estate, the Danish entrepreneur who built the plant (Bigadan A/S), and the energy company E.ON. E.ON purchases the biogas, upgrades it to the quality of natural gas, and distributes it to the gas grid.

The biogas plant at Wråms Gunnarstorp was built according to proven technology and is considered an important part of the estate's work with environmental issues, not least because of the high-quality of the bio-manure. It is practically odour-free and meets the nutrient requirements for all the arable land on the estate. The natural gas grid runs close to the estate which guarantees a market for all the biogas produced. The income from the sale of the upgraded biogas means that the project is profitable even without grants.

The biogas plant and substrate

Apart from pig manure, the substrate includes slaughterhouse waste and waste products from the Findus food processing factory in Bjuv. This factory, which is located 2 km from the estate, produces sludge from its own sewage treatment plant and organic waste products from the food processing facilities. In particular, the pea harvest produces large quantities of organic waste and sludge. These waste products are highly suitable substrates for biogas production. The biogas plant can treat up to 65,000 tons of organic material per year. The substrates are mixed in a receiving tank where they are ground to produce a homogeneous biomass. The material is then pasteurized at 70°C for one hour before it is pumped into the reactor, which has a volume of 4200 m³. The process is mesophilic (38°C), with a retention time of 21 days. The material is then transferred to a second digester tank (1,500 m³ in size), where the remaining biogas is extracted for 6-7 days.

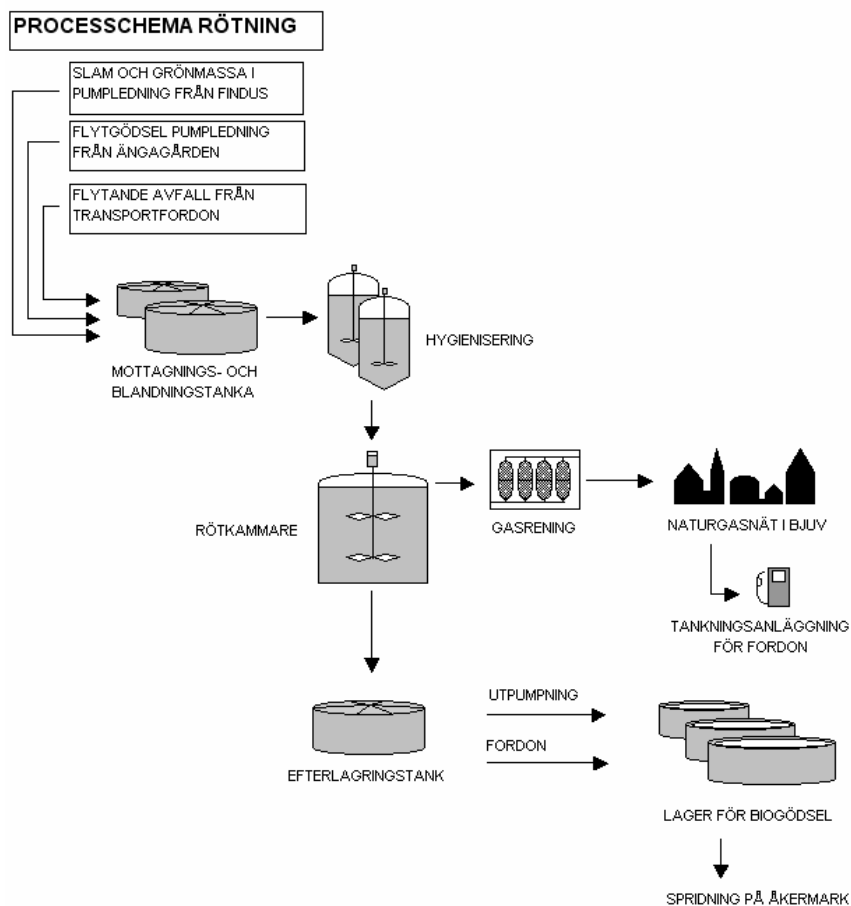

Figure 4.9.2 Process diagram of the biogas plant at Wråms Gunnarstorp, Bjuv

Upgrading and use of the biogas

All the biogas is upgraded to vehicle fuel quality using the PSA-technique. The upgrading plant, which was built at the same time as the biogas reactor, has a capacity of 600-700 Nm³ per hour. Methane leakage is less than 1%. In total, the plant produces 21,000 to 24,000 MWh of upgraded biogas per year, which is equivalent to c. 2.5 million litres of petrol.

Distribution of the biogas

E.ON buys all the biogas produced, purifies it and distributes it on the gas grid. Propane is added to reach the same energy content as natural gas. The upgrading plant is located close to the biogas reactor. The upgraded gas is piped to the gas grid, a distance of c. 3.5 km, through which it is distributed to various end-users and consumers, including gas filling stations. The annual biogas production at the estate is sufficient to supply fuel to 1,200-1,500 gas vehicles.

Bio-manure

After digestion, the bio-manure is stored in five tanks, each with a volume of 5000 m³. From there it is pumped in above-ground hoses several kilometres in length to a specially constructed self-propelled hose spreader, which applies the bio-manure to the land with a capacity of 150 m³ per hour. Approximately 45,000 tons of bio-manure is produced annually, which is spread on the estate's 780 hectares of arable land and other farmland in the neighbourhood. The bio-manure has a relatively low phosphorous content (c. 0.5 kg per m³) and a nitrogen content of 4.5 kg per m³.

Financing

The total investment cost for the biogas plant was 40 million SEK, while the upgrading facility cost 15 million SEK. The project was financed by the three co-owners of Söderåsens Bioenergi AB and one external financier. The project is financially viable without additional grant funding.

Lessons learned

The construction went according to plan, except that the upgrading plant was delayed for two months. This resulted in a loss of sales of biogas at the beginning compared with the original budget. From 2007, the plant is producing at full capacity and the biogas is of high quality (70% methane). The process was started carefully and step-wise, which proved to be a good strategy. To date, the experience with the plant has been positive, and no serious problems have been encountered.

A biogas plant of this size requires careful planning. The biogas project at Wrams Gunnarstorp took 6 years to plan and carry through. It is also important not to take too large a risk initially. The risk can be shared by co-ownership of the company, which is also a good way to ensure the participation of people with different skills. In this case, the upgrading plant is owned by E.ON, which is considered advantageous and a natural way to share risk and responsibility within Söderåsens Bioenergi AB. It is also important to secure long-term access to raw materials and suitable land on which to spread the bio-manure. The production of renewable energy has created a new complementary business niche within the agricultural industry, which is also less sensitive to economic downturns.

Benefits for the environment and society

The biogas plant in Wrams Gunnarstorp is profitable both for the company that runs it and for the environment. The amount of purified biogas produced at the plant is equivalent to a reduction in fossil carbon dioxide emissions of a little more than 4,000 tons per year, which has reduced the total carbon dioxide emissions in the municipality of Bjuv by 3.4%. The estate's advantageous location close to the gas grid means that there is a market for all the biogas produced. The bio-manure produced by digestion is a valuable source of nutrients, so there is less need to buy in mineral fertilizer. Apart from the nutrient content, the bio-manure increases the humus content of the soil, which is particularly valuable for the heavy clay soils that are found across large areas of the estate. The hose spreading technique has reduced the transport of manure by heavy vehicles. Furthermore, complaints are no longer received about the smell of manure following spreading.

Facts 1. Basic data on the biogas plant

Start year (biogas production):	2006
Digester volume:	4 200 m ³
Process temperature:	38 °C
Start year (upgrading):	2006
Upgrading method:	PSA
Investment costs:	55 million SEK

Facts 2. Yearly inputs and outputs

Substrate:	
Pig manure	3 000 tons
Sludge and waste products from Findus	30 000 tons
Slaughterhouse waste	6 500 tons
Biogas:	
From the biogas plant	21 000 MWh
Upgraded biogas	21 000 MWh
Bio-manure:	
Bio-manure	45 000 tons

Contacts

	www.wramsgunnarstorp.com www.eon.se Rudolf Tornerhjelm Telephone: +46 42 705 24 E-mail: rudolf@wramsgunnarstorp.com
--	--

	Staffan Ivarsson, E.ON Telephone: +46 40 25 50 00 E-mail: staffan.ivarsson@eon.se
--	---

Suppliers

Biogas plant:	Bigadan A/S www.bigadan.dk
Upgrading plant:	Carbotech www.carbotech.com

The biogas plant at Hagavik

Facts/unique: Ecological crop production with bio-manure as the sole source of nutrients. Profitable sale of electricity.



Figure 4.10.1 The biogas plant at Hagavik

Hagavik is an arable farm near Malmö producing wheat, barely, rape, peas, beetroots and mange-touts. Mineral fertilizer cannot be used on the farm, because it is run ecologically. Nutrient availability can therefore become limiting, especially as there are no farm animals. The owner, Krister Andersson, therefore decided to build a biogas plant, since bio-manure is a valuable source of nutrients and organic matter. Furthermore, sale of the electricity generated from biogas provides additional income. The biogas plant started operations in 2003.

Hagavik is an arable farm run according to the Swedish KRAV-certification system for ecological agriculture, which means that pesticides and mineral fertilizers cannot be used. The bio-manure produced on the farm therefore makes an important contribution to the soil nutrient status and structure. The biogas is used to heat farm buildings, including a neighbouring farm, and also a grain drier. Only 10% of the electricity generated at the plant is consumed on the farm, so the remainder is sold to the electricity grid. The biogas produced on the farm replaces c. 20 m³ of oil per year. All in all, the construction of the biogas plant at Hagavik has been profitable. It is a good example of a successful farm-scale biogas plant, which is likely to have many imitators.

The biogas plant and substrate

The substrate consists of a mixture of food wastes and chicken manure. New substrate is mixed with liquid taken from the process in a tank before it is pumped into the reactor. The reactor is a continuously-mixed one-step process with a retention time of 100 days. The reactor is 450 m³ in size and the process is mesophilic, running at a temperature of 37°C.

Distribution of the biogas

The biogas is used to generate electricity and heat. Electricity is generated with a 100 kW gas turbine. Approximately 650 MWh is produced annually. The remaining biogas is used to produce heat, c. 200 MWh of which heats the farm buildings, a neighbouring farm, and a grain drier. Only 10% of the electricity generated at the plant is consumed on the farm, so the remainder is sold to Nordpool, the Nordic spot market for electricity. Producers receive one electricity certificate for 1000 kWh of electricity produced with environmentally-friendly techniques. This can be sold on the market to generate income.

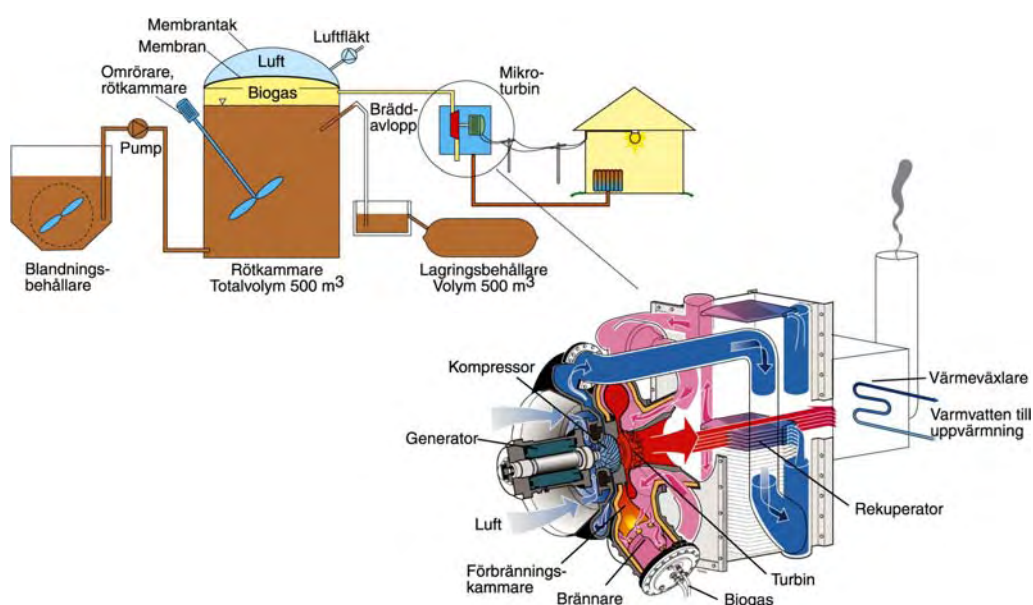

Figure 4.10.2 Process diagram of the biogas plant (Kim Gutekunst, JTI)

Bio-manure

Prior to spreading, the bio-manure is stored in an air-tight rubber sack (500 m³ in size) from where it is pumped to an intermediate storage tank. A conventional liquid manure spreader is used to apply the bio-manure, which has a dry weight content of 6.5% and contains, in each ton, 8 kg of nitrogen, 1.5 kg of phosphorous and 3 kg of potassium. The plant produces c. 1500 tons of bio-manure annually, which is approved for use in ecological agriculture, according to the Swedish KRAV-system.

Financing

The total investment costs for the biogas plant amounted to roughly 4 million SEK. A grant was received for 900,000 SEK, and the rest was self-financed. The price of electricity, and therefore income, varies considerably, but in the long-term the investment will be profitable for the company.

Lessons learned

The plant is working well. In the planning stages, several other established plants were visited, both in Sweden and abroad, to learn about the technique and the various possibilities on the market. Visits were made to biogas plants in Germany, where they have considerable experience of on-farm heat and power production from biogas. This kind of study trip would be even more important for those planning to build a biogas plant for themselves. Combined heat and power production is most profitable when the energy is used on-site.

Benefits for the environment and society

The heat produced at Hagavik replaces c. 20 m³ oil each year. The electricity generated at the plant is distributed on the grid and covers the electricity consumption of more than 60 detached houses. The bio-manure provides both nutrition and humus to the soil, which makes an important contribution to the business, since mineral fertilizer is not allowed in ecological agriculture. The crops grown on the farm are KRAV-certified and of high quality.

Facts 1. Basic data on the biogas plant

Start year (biogas production):	2003
Digester volume:	450 m ³
Process temperature:	37 °C
Start year (electricity generation):	2006
Investment costs:	4 million SEK

Facts 2. Yearly inputs and outputs

Substrate:	
Food wastes	700 tons
Chicken manure	100 tons

Biogas:	
From the biogas plant	2 000 MWh
To electricity generation	650 MWh
To heating	200 MWh
Bio-manure:	
Bio-manure	1 500 tons

Contacts

	Krister Andersson Telephone: +46 40 449 407 E-mail: hagavik@telia.com
--	---

Suppliers

Biogas plant:	Weltec Biopower www.weltec-biopower.de
Gas turbine:	Turbec www.turbec.com

Industrial plants

The biogas process has been used for many years to purify wastewater from some industrial plants. Digesters were installed as long ago as the 1970's and 1980's at a number of sugar factories and pulp and paper mills. There are three biogas plants in Sweden today, which solely digest waste products and process water from manufacturing industries. These are found at the dairy in Umeå, the Domsjö factory in Örnsköldsvik and the sugar factory in Örtofta (Danisco). In addition, there are several other biogas plants that co-digest different substrates from the food industry, for example slaughterhouse wastes, together with other substrates. These are described in the chapter on co-digestion plants, rather than here.

Two industrial biogas plants are described in this handbook, one at Norrmejeriers dairy in Umeå, the other at the bio-refinery 'Domsjö fabriker' outside Örnsköldsvik.

Experiences from industrial biogas plants

Both the environment and the company in question can benefit from treating process water and wastewater in a biogas plant. This is exemplified by the case studies from the bio-refinery in Örnsköldsvik and Norrmejeriers dairy in Umeå.

Apart from the purification of wastewater and process water, energy is produced in the form of biogas. The work carried out in such factories is often energy-intensive. Biogas is therefore an environmentally-friendly and cost-effective alternative to oil, both for heating and electricity generation. Combustion of methane does not produce soot or cinders, which contributes to a cleaner, healthier workplace and minimal wear and tear on boilers and other equipment. Energy self-sufficiency also improves the competitiveness of industry, given uncertainty and rising prices in the oil market.

In general, there is a great potential to increase biogas production from the food industry. One example is the energy-rich waste from slaughterhouses which produces large quantities of biogas per volume. Slaughterhouse waste is already in demand as a substrate at co-digestion biogas plants.

One important aspect is how the residue from industrial plants can be marketed. If the substrate is relatively 'clean' then the final product will also be of high quality, and could be widely used, most advantageously within agriculture.

The biogas plant at Domsjö fabriker

Facts/unique: The largest producer of biogas in Sweden. High quality biogas with a methane content of 85%.

The bio-refinery 'Domsjö fabriker' is located in Örnköldsvik, on the shore of a bay of the Baltic Sea. Paper pulp has been produced here since 1903. In recent years, production has developed away from traditional paper pulp as the main product to an advanced bio-refinery which manufactures special celluloses, ethanol and ligno-sulphonate. Environmental issues have been a top priority for many years, and the company has a well developed environmental policy which prescribes effective exploitation of raw materials, chemicals and energy to support sustainable development in the long-term. One example of this is that the factory was the first in the world in 1991 to bleach cellulose in a closed system. Chlorine-free bleaching has been practiced since 1990. As one part of the company's environmental efforts, Sweden's then largest biological waste treatment plant was opened in 1985. In this plant, wastewater is treated in two stages, the first of which is anaerobic digestion to produce biogas, and the second is an aerobic step with free access to oxygen.



Figure 5.11.1 The biogas plant at Domsjö. The blue and white tanks are anaerobic digesters and the polished steel container is a de-gassing tank.

The plant at Domsjö fabriker is the largest single producer of biogas in Sweden (in terms of MWh biogas produced). The biological treatment plant is highly efficient, purifying 2,070,000 m³ of wastewater annually. The personnel are continuously trained in environmental issues. The conscious efforts at the company to improve the environment have had noticeably positive effects on ecological conditions in the bay of Örnsköldsvik. The biogas process is an important component of this work.

The biogas plant and substrate

Wastewater from the bio-refinery 'Domsjö fabriker' and from nearby chemical plants run by Akzo Nobel and Sekab is used as substrate for the first anaerobic step in the biological treatment process. The biogas plant treats 2,070,000 m³ of wastewater annually, but there is sufficient capacity to treat more. Digestion takes place in two reactors with a total volume of 30,000 m³, with continuous mixing. The retention time is 3 days in the anaerobic step, which has a process temperature of 37°C.

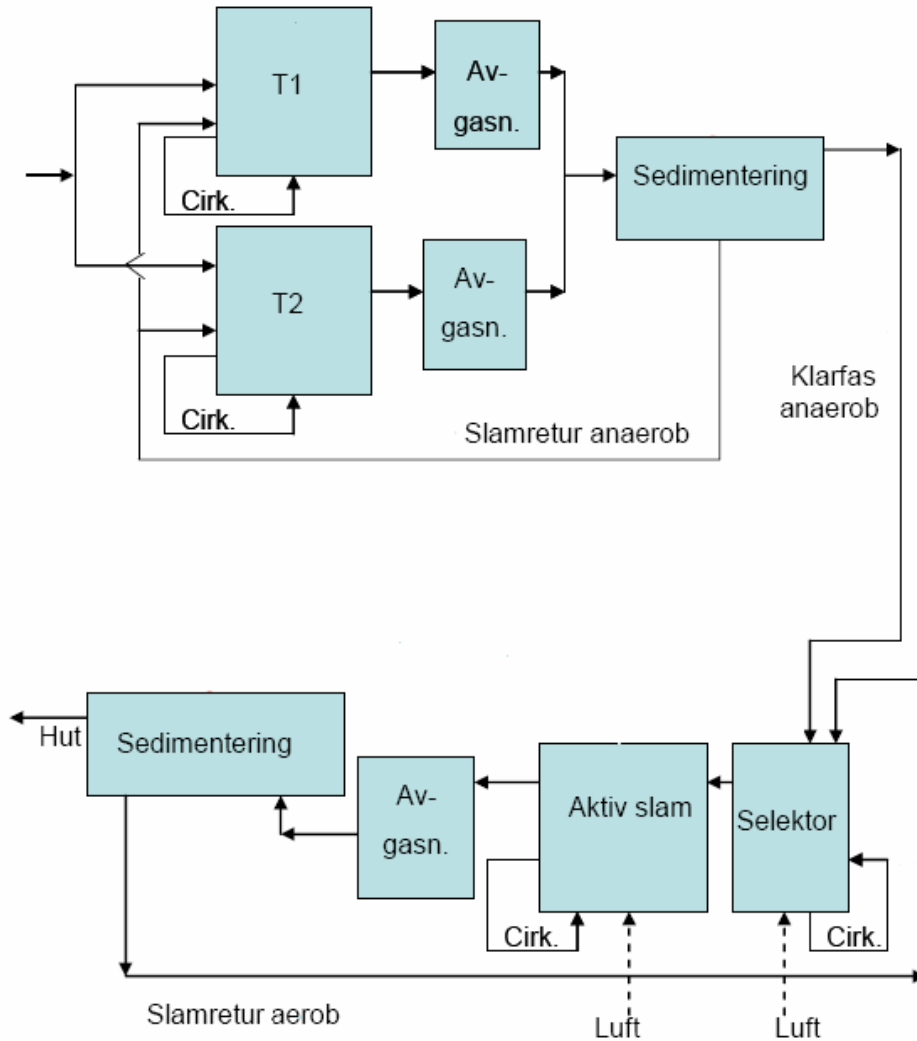

Figure 4.11.2 Process diagram of the biogas plant at Domsjö. T1 and T2 are two parallel anaerobic digesters. The aerobic step commences with the selector.

Use and distribution of the biogas

The biogas plant produces a little more than 85,000 MWh of biogas per year. The gas has a high quality, with a methane content of 85%. The energy in the biogas is exploited within the company for heating using a steam boiler. Less than 1% of the biogas is flared off. The biogas will soon be used to produce power and heat, with part of the electricity used internally, and the rest sold on the grid.

Digestion residue

After anaerobic digestion, the wastewater moves on to an aerobic step where the decomposition of the substrate continues in aerated basins. The sludge produced from the anaerobic digestion step is returned to the process as it contains active microorganisms that are critical for the process. The sludge from the aerated step (c. 2,500 tons annually) also contains bacteria and other suspended material and is used to manufacture soil conditioners.

Financing

The total investment cost for the biogas plant was 72 million SEK (in 1985). Since then, several extensions to the plant have been built, with the costs shared with Akzo Nobel and Sekab, in proportion to the waste volumes supplied by each company.

Lessons learned

The biogas plant is continuously being developed and improved to remove bottlenecks and increase the capacity to accept more wastewater. Decomposition of the organic substrate is already very efficient, and the plant produces large amounts of biogas. It is now possible to catch salmon in the bay close to the industrial area, and thanks to the production of biogas, the plant is now using much less fossil fuel. One problem that can sometimes occur during anaerobic digestion is that the composition of the industrial wastewaters can vary considerably, which may occasionally cause foaming and loss of sludge.

Benefits for the environment and society

The efficient biological treatment of industrial wastewaters from Domsjö fabriker, Akzo Nobel and Sekab has resulted in much cleaner discharges from these factories. Measurements show that ecological conditions in the bay of Örnköldsvik have improved, and the lake bottoms in this area have been re-colonised. Salmon are once again swimming up the Mo river. The energy in the biogas replaces large quantities of fossil oil that were earlier used in manufacturing at the Domsjö fabriker.

Facts 1. Basic data on the biogas plant

Start year (biogas production):	1985
Digester volume:	2 x 15 000 m ³
Process temperature:	37 °C
Total investment costs:	72 million SEK

Facts 2. Yearly inputs and outputs

Substrate (capacity):	
Wastewater from Domsjö	1 930 000 m ³
Wastewater from Akzo Nobel	183 000 m ³
Wastewater from Sekab	256 000 m ³
Biogas:	
From the biogas plant	85 000 MWh
Digestion residue:	
Soil products after aeration step	2 500 tons

Contacts

	www.domsjoe.com
	Cecilia Geijer Telephone: +46 660 756 41 E-mail: cecilia.geijer@domsjoe.com
	Patrik Svensson, miljöchef Telephone: +46 660 755 70 E-mail: patrik.svensson@domsjoe.com

Norrmejerier's biogas plant in Umeå

Facts/unique: Producing biogas from whey from cheese-making. Biotrans-technology optimises both purification and energy extraction

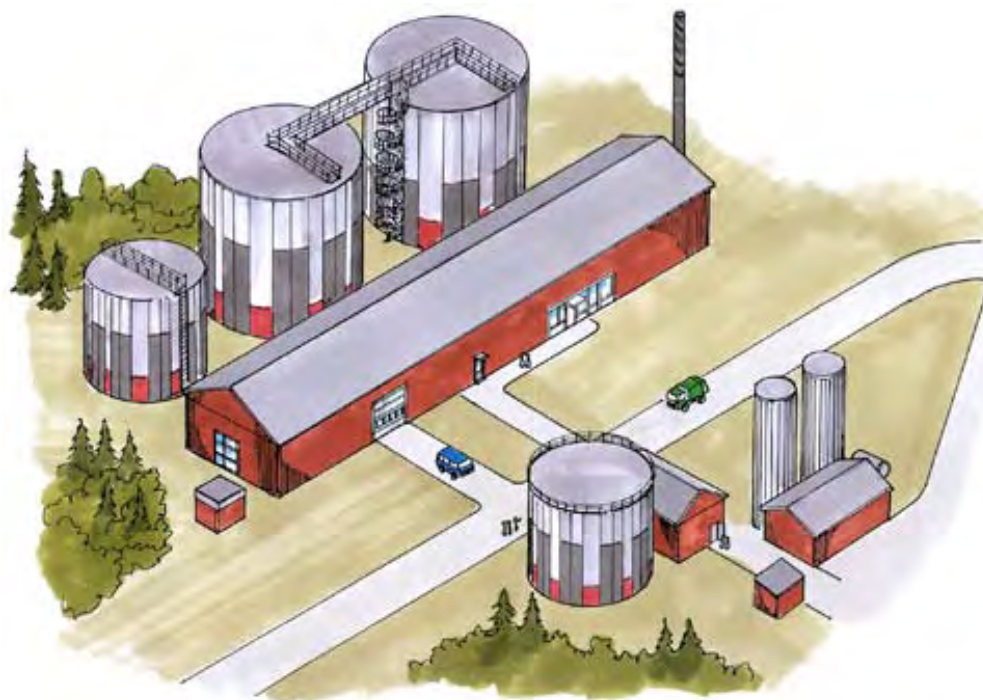

Figure 4.12.1 The biogas plant in Umeå

Whey and other waste products from cheese-making are used as substrates to produce biogas at Norrmejerier's dairy near Umeå. In making cheese, roughly 90% of the milk becomes whey. Dealing with such large quantities of whey can be problematic. Traditionally, this waste product is fed to animals. After studying new technologies at dairies in Germany, Switzerland and Belgium, the management at Norrmejerier decided instead to further refine the whey using ultra-filtration. With

this method, most of the proteins in the whey are removed by filtration. These proteins are valuable as a raw material in producing new food products. Together with wastewater and other waste products, the remaining whey is anaerobically digested to produce biogas. This system optimizes the purification of the various waste products and also the extraction of energy from them. The biogas plant started operations in the spring of 2005, as a result of a collaboration between Norrmejerier, SIK, CIT Industrial Analysis and the Centre for Membrane Technology at Lund Technical University.

The 'Biotrans'-plant at Norrmejerier is the first in Sweden, and one of only a few in Europe, that makes effective use of whey by extracting the valuable proteins and using the by-product to produce energy from biogas. The investment in this technology benefits the environment, and is also financially advantageous for the dairy, because it has saved money on oil and has also been able to increase production capacity.



Figure 4.12.2 Turning the cheese at the dairy in Burträsk

The biogas plant and substrate

The substrate consists of whey from the dairy in Burträsk, 100 km north of Umeå, and whey and other waste products from the dairy in Umeå. The substrate is first passed through a hydrolysis chamber (800 m³) before it is pumped into the biogas reactor. The fat is then removed by flotation separation. This fat is digested separately in two mesophilic reactors (35°C), each 100 m³ in size, with a retention time of 22 days. The remaining material is digested in a 'contact process' in two

reactors with a total volume of 5000 m³. This means that the effluent is returned to the process via sedimentation in a so-called 'clarifier'. This maintains the density of bacteria in the reactor, which means that the retention time for the liquid can be kept short (3.6 days) with no risk of loss of bacterial culture. The process temperature in these reactors is also 35°C.

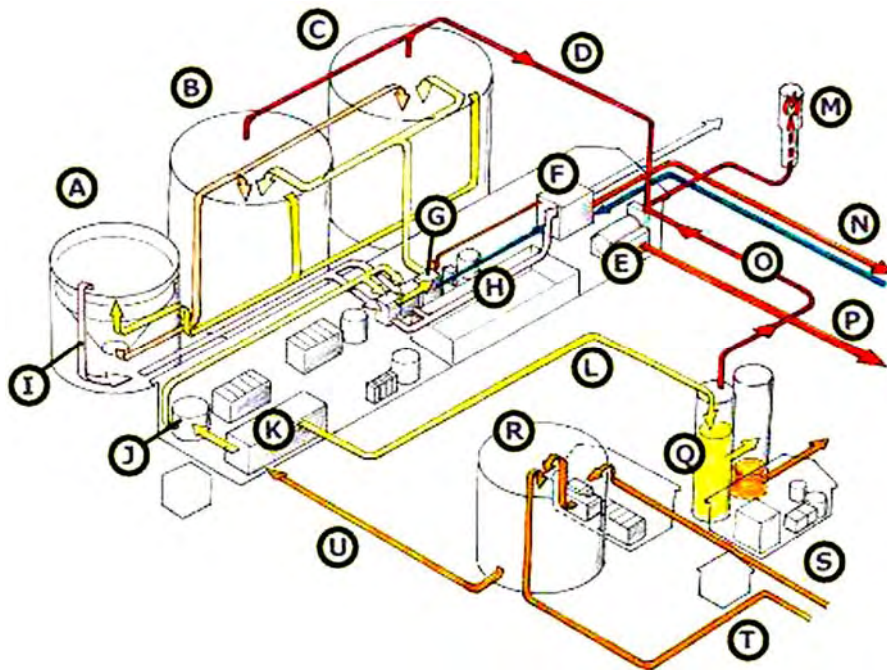

Figure 4.12.3 Process diagram of the biogas plant in Umeå

Use and distribution of the biogas

The biogas replaces oil, and is used to produce steam in a boiler. About 10,000 MWh of biogas is produced annually. A further 7,000 MWh is obtained in the form of heat from the effluent using a heat pump.

Digestion residue

The sludge that goes into the clarifier after digestion is cooled in a heat pump to 15°C and then stored. The store is emptied at night, and the sludge transported to the sewage treatment plant in Umeå. In total, c. 400 tons of sludge (dry weight) is produced annually. In turn, the digestion residues from Umeå sewage treatment plant are used to manufacture a filler material ('sludge pellets') that is used in construction (e.g. roads).

Financing

The total investment cost for the biogas plant including the filtration facility was 90 million SEK. Of this, Norrmejerier paid 80 million, the county council of Västerbotten paid 8 million and the EU paid 2 million. The investment is expected to be repaid within 6 years, thanks to the energy savings and an improved use of raw materials.

Lessons learned

The plant is working according to expectations. The entrepreneur underestimated the amount of biogas that could be produced from whey, which means that the investment will be re-paid earlier than expected (6 years). Management consider the project a success and would recommend this technology to other businesses with similar problems. However, the circumstances in each particular case should be analysed very carefully and the advantages and disadvantages of the various technical solutions examined. A few teething problems occurred in coordinating the steam boiler, the heat pump and the process. The plant has attracted much attention, and has received many visitors both from Sweden and abroad.

Norrmejerier are also planning to build another plant to treat the digestion residue aerobically in a final purification step, including sludge thickening. Norrmejerier would then have a complete purification plant and would not have to rely on the municipal treatment plant. As the substrate is clean, the final product would be a bio-manure of high quality, which could be used to produce topsoil, for example. This plant will be built in the autumn of 2008.

Benefits for the environment and society

Norrmejerier are replacing oil with biogas, saving c. 2,500 m³ oil each year. This is partly due to the energy in the form of steam extracted from the biogas and partly because the whey is treated more efficiently in the 'Biotrans' process. The process also extracts valuable proteins from the large quantities of whey produced by cheese-making. Similar plants in other countries have mostly focused on wastewater purification, but the Norrmejerier dairy has optimized both purification and energy production. In addition, less sludge is sent to the municipal sewage treatment plant, which helps both the environment and the local authority.

Facts 1. Basic data on the biogas plant

Start year (biogas production):	2005
Digester volume:	2 x 2 500 m ³ , 2 x 100 m ³
Process temperature:	35 °C
Total investment costs:	90 million SEK

Facts 2. Yearly inputs and outputs

Substrate:	
Whey	2450 tons dry weight (35,000 tons wet weight)
Milk waste products/process water	2700 tons dry weight
Biogas:	
From the biogas plant	10 000 MWh

From the heat pump	7 000 MWh
Digestion residue:	
Sludge pellets from the treatment plant	400 tons dry weight

Contacts

	<p>www.biotrans.se</p> <p>Tony Bäckström, driftansvarig Telephone: +46 90 18 28 12 E-mail: tony.backstrom@norrmejerier.se</p> <p>Olle Sjöstedt, miljöansvarig Telephone: +46 90 18 29 54 E-mail: olle.sjostedt@norrmejerier.se</p>
--	--

Suppliers

Biogas plant:	<p>Enviro-Chemie www.envirochemie.com</p> <p>Peab www.peab.se</p> <p>YIT www.yit.se</p> <p>Bravida www.bravida.se</p>
---------------	--

General conclusions and lessons learned

This chapter gives a brief summary of some lessons learned and experiences gained from biogas production in Sweden. Detailed case studies are presented in Chapter 4.

It is very important to secure long-term access to raw materials before starting operations. Contracts with suppliers should be drawn up.

The objective should be to utilize all of the biogas produced. Local and regional markets for biogas should be carefully investigated before starting operations.

With current Swedish market prices, combined power and heat production from biogas is most profitable if the heat and electricity can be used on-site (i.e. within the company).

Upgrading biogas to vehicle fuel quality requires relatively large investments. On the other hand, the demand for upgraded biogas is continually increasing, so that such investments can be profitable in the long-term.

Economies of scale can be achieved if several biogas producers together invest in an upgrading plant, for example in the case of farm-scale digestion. A distribution system is needed to enable each producer to deliver raw gas to the upgrading plant, as well as a system to distribute upgraded gas to final customers.

It is important that the digestion residues and bio-manure find suitable markets. Contracts with buyers may be necessary. The Swedish certification system for bio-manure is an excellent means of 'quality assurance', increasing its application in agriculture.

Bio-manure is a valuable resource for many agricultural businesses and provides an important supply of humus and nutrients to the soil, especially in ecological agriculture. The nitrogen in bio-manure is also easily available for plants. Compared with fresh undigested material, bio-manure does not suffer from problems with odour, which is a major advantage when spreading on land close to built-up areas.

There is a large capacity to increase biogas production from sewage treatment plants that in most cases is yet to be exploited. By optimising process conditions, more biogas can be extracted per volume of reactor. Many sewage treatment plants are also planning to increase production of upgraded biogas and improve the quality of the digestion residue.

Biogas is a fuel which is in demand from industry, partly because it is a gas which means that it is easily regulated and has a high combustion capacity. The methane molecule can also be used as a raw material in many industrial processes. Replacing oil with biogas improves the environment and enables companies to become self-sufficient in energy.

A strong commitment and broad political support from local authorities, for example by encouraging the purchase of biogas vehicles, promotes the wider development of biogas. Close collaboration between various partner organisations and individuals is required to ensure that the entire system functions properly, from the supply of substrate to the distribution of biogas and bio-manure.

There is a great deal of international interest in biogas technology. Strong support to develop the domestic market would help Swedish biogas companies expand and become successful on the international market.

The biogas puzzle has many pieces

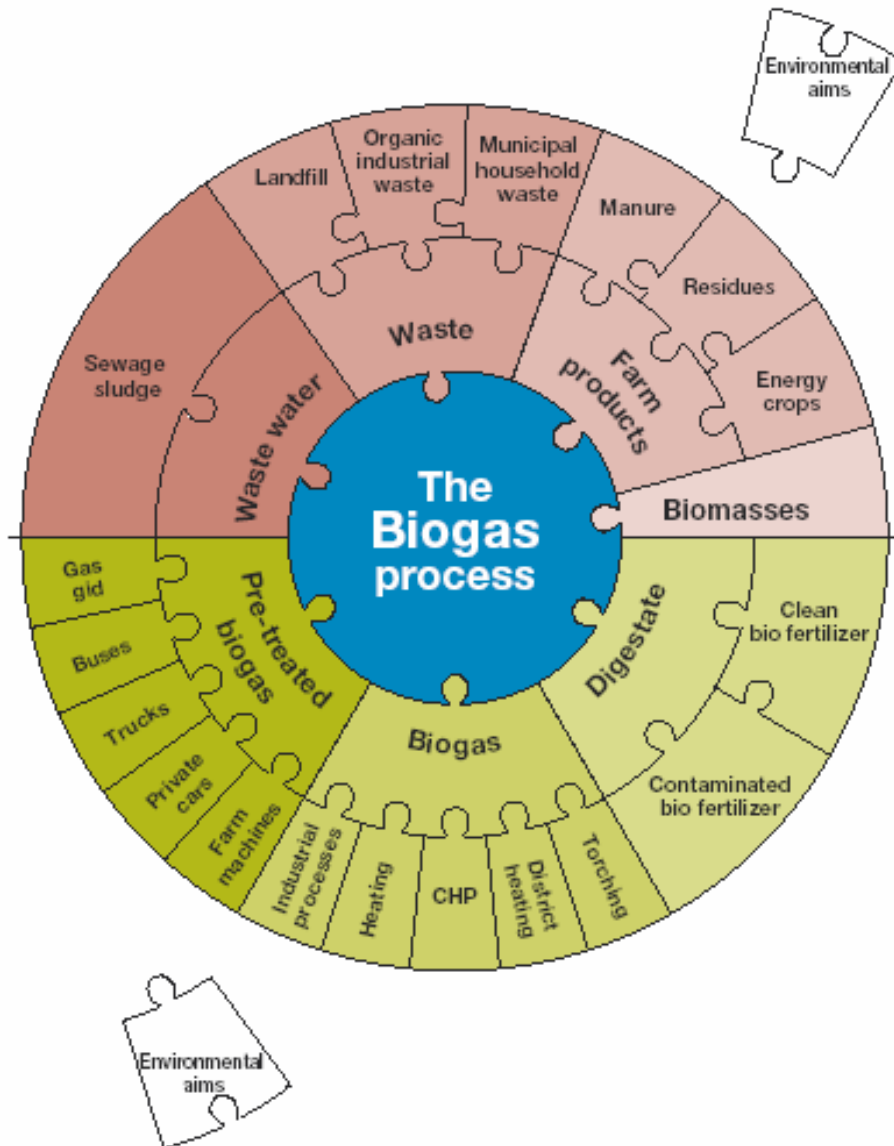

Figure 5.2.1 The biogas process has many pieces

Biogas can play an important and many-faceted role in helping companies and local authorities to provide environmentally-friendly solutions in diverse fields such as greenhouse gas emissions, energy planning, public transport, biodiversity, the management of organic wastes and the influence of urban areas and agriculture on the environment. The biogas process takes place naturally in oxygen-free environments. It has been used by humans under controlled conditions for more than 100 years and the technology is continuously improving. It is today a technology in harmony with the sustainable society of the future.

A biogas project can be compared to the many pieces of a puzzle that, with time, can be placed together one after another, and adapted to the local conditions.

Wastewater

Sewage sludge

Biogas has been produced at sewage treatment plants in Sweden since the 1940's, and most of the ca. 140 plants in Sweden today are of this type. The gas that is produced is of high quality. Concentrations of some contaminants in the final residue or digestion sludge are unfortunately too large to allow its use as a fertilizer in food production.

Waste

Landfills

Biogas has been extracted from landfills in Sweden since the 1980's, and there are ca 60 plants operating today. The biogas produced is contaminated with nitrogen from the air, and is therefore of moderate quality. The deposition of biodegradable waste in landfills was banned in 2005.

Organic wastes from industry and households

Ca. 10 co-digestion plants have been built in Sweden since the 1990's, which utilize different types of organic wastes as raw material. In some cases, a greater control is exercised on the quality of the substrate, which means that the digestion residue can be quality-assured and can be used as a soil conditioner and fertilizer in agriculture (so-called bio-manure).

Agricultural products

The total potential production of biogas in Sweden is estimated at ca. 14 TWh. Of this, a little more than 80% originates from the agricultural sector. Manure, which is produced in large quantities in agriculture, is an excellent raw material for biogas production. Waste products of crop production (e.g. potato and sugar beet tops) and clover leys grown in ecological farming systems are also good substrates. Other materials that can be used to advantage include biomass harvested from fields under 'set-aside', and bio-energy crops such as clover and grass leys, lucerne, maize or cereals.

Other raw materials

Many unconventional raw materials can also be used in the biogas process, including vegetation removed from drainage ditches along roads, raw materials from forests, reeds etc.

Upgraded biogas

If the biogas is to be used as vehicle fuel or distributed through the gas grid, it must first be purified from corrosive components, particulate matter and water, and the

energy content must be increased by removing carbon dioxide. The two commonest upgrading techniques are the water wash method and PSA (pressure swing adsorption). There are more than 30 upgrading plants for biogas in Sweden. Gasol can be added to compensate for variations in the quality of the upgraded biogas. In many cases, this is a reliable and cost-effective solution.

Filling stations

There are today ca 90 filling stations for vehicle gas in Sweden and many more are being planned. Most of the filling stations are located in southern Sweden. Vehicle gas is also available in most European countries. Filling a gas-driven private car is just as easy as filling up with petrol.

Vehicles

Gas-driven vehicles have lower running costs and can be driven on both natural gas and biogas since they are chemically identical. The difference is that biogas is renewable. Biogas is today the most environmentally-friendly vehicle fuel on the market. There are now 18 different makes of gas-driven private cars on the Swedish market, and more will be available soon. These cars are Bi-fuel, which means that they can be switched between petrol and gas to maintain flexibility. Buses and trucks can also be run on gas. They are much quieter than diesel-driven vehicles and also produce a much cleaner exhaust, which is important in city traffic environments.

Biogas

Biogas is produced when organic material (manure, food wastes, plants, sewage sludge etc.) is decomposed by microorganisms in an oxygen-free environment. Biogas mainly consists of methane and carbon dioxide, but also contains small amounts of hydrogen sulphide and ammonia. Biogas is continuously produced in natural environments such as the stomach of cows and other ruminants, in marshes and bogs and in lake sediments. The active microorganisms in the biogas process can be controlled using bio-engineering techniques to produce renewable energy from wastes in the form of methane. Raw biogas can be used in boilers and engines to generate heat and electricity. Surplus gas must be 'flared off'.

Digestion residues

Clean manure

Nitrate leaching is a severe environmental problem in modern agriculture, causing eutrophication of water-courses, lakes and seas. One of the reasons for this problem is that the nutrients in the manure spread on agricultural land are not efficiently exploited by crops. Anaerobic digestion converts much of the bound nitrogen to forms that are more easily available for plants. This is especially valuable in ecological farming, where manure must be used since mineral fertilizers are not allowed. The use of uncontaminated waste products from the food industry and

source-sorted household wastes allows quality assurance of the bio-manure, and thus the possibility to return plant nutrients to agriculture. Bio-manure that has been anaerobically digested also smells much less than fresh manure.

Contaminated manure

The digestion residue from plants that cannot control the quality of the substrate (e.g. sewage treatment plants) is called sludge rather than bio-manure. Sludge cannot be approved as fertilizer on agricultural land used for food production, but can be used, for example, to fertilize bio-energy crops.

Frequently asked questions

1. What is biogas?

Biogas is formed in a natural process when organic material (plants, food wastes, manure etc.) is decomposed by micro-organisms in an anaerobic (i.e. oxygen-free) environment. Anaerobic decomposition takes place in landfills (landfill gas) and different types of biogas plants (digestion gas). Biogas is also produced in natural environments where the availability of oxygen is limited, for example in bogs and marshes, rice paddies and in the stomachs of ruminants. Raw biogas mostly comprises methane and carbon dioxide, but it also contains small amounts of other gases, such as nitrogen, ammonia and hydrogen sulphide. Biogas is usually saturated with water vapour. Methane is responsible for the energy-rich part of biogas. The methane content in biogas varies between 45 and 85% depending on the origin of the digested material.

2. What is biomethane?

Biomethane is a term used to describe gases containing methane that can be extracted from biological material, for example by anaerobic digestion or by thermal gasification of cellulose-rich material (e.g. woody raw materials or carbon-rich wastes). Controlled heating of the material in a closed system, either with or without pressurization, produces gases, among them methane, which can be collected for further processing.

3. What is the difference between biogas and natural gas?

Biogas and natural gas are both products of the microbial decomposition of organic material in an oxygen free environment. The difference is that biogas is produced from the turnover of organic material circulating above the earth's crust today, whereas natural gas is the result of a similar oxygen-free decomposition of organic material that took place millions of years ago, so that the gas is now locked deep down in fossil layers. Another difference is that natural gas has a very high content of methane (at least 90%), while the methane content of raw biogas is smaller.

4. What is biogas used for?

Biogas has many uses. For example, it can be used as a fuel in gas fires and ovens and for heating, either locally or through district heating networks. Biogas can also be used to generate electricity, thereby contributing to an increase in the proportion of 'green' electricity in the electricity grid. Biogas is also the best alternative vehicle fuel on the market, from both economic and environmental points of view. The use of biogas as a vehicle fuel is increasing from year to year, both in Sweden and abroad. Biogas also has industrial uses, both as a fuel and as a raw material in manufacturing.

5. What do the combustion exhausts contain?

Biogas is a very clean fuel, with negligible emissions of carbon monoxide, hydrocarbons, sulphur compounds, nitrous oxides, trace metals and particulate matter. The combustion of methane produces mainly carbon dioxide and water vapour. The combustion of biogas involves no net input of carbon dioxide to the atmosphere, since it is a biofuel.

6. When must biogas be upgraded?

The energy content of biogas must be increased if it is to be used as a vehicle fuel. This is called upgrading. Water and contaminants such as hydrogen sulphide and particulate matter must also be removed. Finally, the gas must be compressed or pressurized to c. 200 bars before it can be used as a fuel. Upgraded biogas has a methane content of at least 95%, and can therefore be used in the same way as natural gas. Upgraded biogas can also be distributed through the gas grid. A higher hydrocarbon, usually propane, is added to the upgraded biogas in order to obtain the same energy content as natural gas, before they are mixed in the grid.

7. What is vehicle gas?

Biogas and natural gas are collectively called vehicle gas when they are used as a vehicle fuel. Vehicle fuel consists mostly of methane. Biogas is renewable and carbon dioxide neutral. Although natural gas is a fossil fuel, it is more environmentally-friendly than either petrol or diesel. Biogas represents more than half of the vehicle gas used in Sweden today, and this proportion is steadily increasing.

8. Why is biogas in demand from industry?

Methane burns with a clean and pure flame, which means that boilers and other equipment are not clogged by soot and cinders. This leads to a cleaner workplace environment and less wear and tear on the plant. The methane molecule can also be used as a raw material in many different manufacturing processes, with diverse final products such as paints, plastics, furniture, animal feeds and lubricant oils. Companies can become self-sufficient in heat and electricity by producing their own biogas from the anaerobic digestion of various organic wastes and process waters from industrial processes. This decreases the dependence on imported oil, which can be an important strategic step towards improving the long-term competitiveness of the company.

9. Is biogas dangerous?

The two main components of biogas, methane and carbon dioxide, are both non-toxic and odour-free. If raw biogas smells, it is usually because of trace amounts of various sulphur compounds, especially hydrogen sulphide. Hydrogen sulphide is poisonous at high concentrations, but when the biogas process is properly managed, concentrations of this gas are very small. Hydrogen sulphide is removed

when biogas is upgraded, along with other contaminants. Thus, upgraded biogas is non-toxic and odour-free. Upgraded biogas contains a scented additive to enable easy detection of gas leaks.

Methane is a safer fuel than petrol or diesel, because the gas is not poisonous and is lighter than air. In the event of a leak, the gas quickly rises and becomes diluted in the surrounding air. Furthermore, biogas has a higher temperature of ignition than petrol and diesel, which reduces the risk of fires and explosions at accidents. Gas cars are tested in the same way as petrol-driven cars. The fuel system is 'closed', which eliminates leaks during filling.

10. What happens in a biogas process?

In the biogas process, many different microorganisms participate in a complex web of interacting processes which result in the decomposition of complex organic compounds such as carbohydrates, fats and proteins to the final products of methane and carbon dioxide. The biogas process can be divided into three main steps. In the first step (hydrolysis), microorganisms, aided by enzymes, decompose the complex organic compounds to simpler compounds such as sugar and amino acids. A number of intermediate products are formed in the next step (fermentation), including alcohols, fatty acids and hydrogen gas. Methane is formed in the last step by a unique group of microorganisms (methanogens) that have very specific environmental requirements. Methanogens grow slowly and die if they come into contact with oxygen. They also need access to certain vitamins and trace elements and are sensitive to rapid changes in temperature, acidity (pH) and other environmental factors. In starting and running a biogas process, it is very important to be aware of the nature of the biological processes involved, and to adapt the technology to meet the environmental and nutritional requirements of the microorganisms.

11. What materials can be used to produce biogas?

Biogas can be produced from many different kinds of organic material including, for example, food wastes, manure, sludge from sewage treatment plants, slaughterhouse waste, process water from the food industry and crop residues. Different substrates are often co-digested, which usually produces biogas of higher methane content, than when individual substrates are digested separately.

12. Does biogas production compete with food production?

No direct competition with food production will occur if the land that is today in set-aside (10-15% of the cultivated area) is instead used to grow crops for bio-energy. Instead, growing crops for biogas is an effective way of utilizing the land, maintaining its capacity for future crop production. Furthermore, arable land is most effectively utilized when the by-products of food production such as tops and other crop residues are used to produce biogas.

13. What is digestion residue?

The organic material is rarely completely decomposed in a biogas process. A digestion residue is therefore formed, which apart from water and organic material, also contains microorganisms and various nutrients. This nutrient-rich final product can be used as fertilizer. The residue is also a good soil conditioner as it adds organic matter to the soil.

14. What is the difference between digestion residue and bio-manure?

Digestion residue is a collective name for all kinds of solid residues formed after anaerobic decomposition of organic materials. This includes, for example, the digestion residue from sewage treatment plants, so-called sewage sludge, but it could also be the final product of the digestion of manure on a farm. The residue obtained from biogas reactors that digest relatively uncontaminated materials (e.g. source-sorted food wastes, manure, crops, process water from the food industry etc.) is usually called bio-manure. It has a similar consistency to liquid manure produced by cattle and pigs. Bio-manure has very low concentrations of trace metals and other contaminants, which makes it highly suited as a fertilizer and soil conditioner in agriculture.

15. Why does biogas contribute to sustainability?

The biogas process takes care of society's waste products (food wastes, sewage sludge, manure, various wastes from the food industry etc.) and returns energy in the form of biogas and nutrients in the form of bio-manure. In this way, organic wastes become a resource in the recycling of energy and nutrients between urban and rural areas, and between production and consumption.

16. Does biogas production increase emissions of greenhouse gases to the atmosphere?

No. Methane is a greenhouse gas, but it is rendered harmless when it is combusted to produce carbon dioxide and water. However, methane leaks arising during the handling of biogas and biomanure should be avoided. Fresh pig and cattle manure produce both methane and nitrous oxide, which is another greenhouse gas. By digesting the manure, the methane can be collected and used. Thus, losses of methane from digested bio-manure are much smaller than from fresh manure. The nitrogen in bio-manure is also easily available to plants, so that it can be quickly taken up by the roots. This means that the risk for losses of ammonia and nitrous oxide is smaller than when fresh manure is spread on the land.

17. Is biogas production profitable?

Replacing oil with biogas realizes benefits for both the environment and for businesses. However, with the current price of electricity on the Swedish market, combined heat and power production is the most profitable use of biogas if the heat

and electricity generated can be used internally within the company. Upgrading biogas to vehicle fuel quality requires relatively large investments. On the other hand, the demand for upgrade biogas is continually increasing, which means that such investments can be profitable in the long-term. Economies of scale can be achieved if several companies collaborate in establishing upgrading plants and distribution networks. The profitability of Swedish co-digestion plants depends on many factors, many of which can be difficult for individual plants to control. The price of petrol is an important factor for biogas plants producing vehicle fuel. Profitability is also affected by contracts that biogas plants enter into with waste management and energy companies. Many of these biogas projects would not have been possible without financial contributions from LIP and KLIMP. However, in the long term, these biogas plants should become profitable.

Lists

Suppliers / Consultants /Business partners

Company	Address	Homepage	Business
AnoxKaldnes AB	Klosterängsvägen 11 A S-226 47 Lund	www.anoxkaldnes.com	Consultant
BioMil AB	Trollebergsvägen 1 S-222 29 Lund	www.biomil.se	Consultant
Bioprocess Control Sweden AB	Ole Römers väg 12 S-223 70 Lund	www.bioprocesscontrol.se	Consultant
BIOSYSTEM AB	Snöån Skuthagen 4 S-771 90 Ludvika	www.biosystem.se	Consultant
Dresser Wayne AB	Box 30049 S-200 61 Malmö	www.wayne.se	Supplier
E.ON Gas Sverige AB	Nobelvägen 66 S-205 09 Malmö	www.eongas.se	Business partner
Euromekanik	Box 171 04 S-402 61 Göteborg	www.euromekanik.se	Supplier
Flotech Sweden AB	Tullgårdsgatan 8, nb S-116 68 Stockholm	www.flotech.com	Supplier
FVB Sverige AB	Isolatorvägen 8 S-721 37 Västerås	www.fvb.se	Consultant
Grontmij AB	Carl Gustafs väg 4 S-205 09 Malmö	www.grontmij.se	Consultant
Läckeby Water Group AB	Mosekrogsvägen 2 S-380 31 Läckeby	www.lackebywater.ab	Supplier
Malmberg Water AB	Gamla byvägen 41 S-296 85 Åhus	www.malmberg.se	Supplier
Processkontroll AB	Box 2088	www.processkontroll.com	Supplier

	S-444 02 Stora Höga		
Ramböll Sverige AB	Östra vägen 1 S-462 32 Vänersborg	www.ramböll.se	Consultant
Scandinavian Biogas Fuels AB	Verkstadsgatan 4 S-753 23 Uppsala	www.scandinavianbiogas.se	Consultant / Business partner
SWECO AB	Box 34044 S-100 26 Stockholm	www.sweco.se	Consultant
Swedish Biogas International AB	Södra Oskarsgatan 3 S-582 73 Linköping	www.swedishbiogas.eu	Consultant / Business partner
VA-Ingenjörerna AB	Trädgårdsgatan 15 S-702 12 Örebro	www.vaing.se	Supplier/ Consultant
Vattenfall Power Consultant AB	Box 475 S-401 27 Göteborg	www.vattenfall.se	Consultant
ÅF Ångpanneföreningen	Box 8309 S-104 20 Stockholm	www.af.se	Consultant
OP System AB	Box 75 S-260 21 Billeberga	www.opsystem.se	Supplier
Fordonsgas Sverige	Andra personsgatan 14 S-416 64 Göteborg	www.fordonsgas.se	Business partner
Svensk Biogas AB	Box 1500 S-581 15 Linköping	www.svenskbiogas.se	Business partner

Trade organisations

Trade organisation	Name	Email	Homepage
Svenska Gasföreningen	Annika Koningen	annika.koningen@gasforeningen.se	www.gasforeningen.se
Svenska Gasföreningen	Helena Jansson	helena.jansson@gasforeningen.se	www.gasforeningen.se
Svenska Gasföreningen	Stefan Dahlgren	stefan.dahlgren@gasforeningen.se	www.gasforeningen.se
Svenska Biogasföreningen	Stefan Dahlgren	info@sbgf.info	www.sbgf.info
Svenska	Anders Nylander	anders.nylander@biogassyd.se	www.sbgf.info

Biogasföreningen			
Avfall Sverige	Hanna Hellström	hanna.hellstrom@avfallsverige.se	www.avfallsverige.se
Biogas Väst	Bernt Svensén	bernt.svensen@businessregion.se	www.brgbiogas.se
Biogas Väst	Hans Larsson	hans.larsson@businessregion.se	www.brgbiogas.se
Lantmännens Riksförbund	Lars-Gunnar Johansson	lars-gunnar.johansson@lrf.se	www.lrf.se
Biogas Syd	Anna Hansson	anna.hansson@biogassyd.se	www.biogassyd.se
Biogas Syd	Kjell Christensson	kjell.christensson@biogassyd.se	www.biogassyd.se
Biogas Syd	Gabriella Eliasson	gabriella.eliasson@biogassyd.se	www.biogassyd.se
NGVA Europé	Peter Boisen	peter@boisen.se	www.ngvaeurope.eu
Svenskt Gastekniskt Center	Anneli Petersson	anneli.petersson@sgc.se	www.sgc.se
Svenskt Gastekniskt Center	Jörgen Held	jorgen.held@sgc.se	www.sgc.se
Svenskt Gastekniskt Center	Mattias Svensson	mattias.svensson@sgc.se	www.sgc.se
Svenskt Gastekniskt Center	Staffan Karlsson	staffan.karlsson@sgc.se	www.sgc.se
Svenskt Vatten	Anders Lind	anders.lind@svensktvatten.se	www.svensktvatten.se
Bioenergiportalen	Carina Johansson	carina.johansson@jti.se	www.bioenergiportalen.se

Upgrading plants in Sweden

Plant name	Municipality	County	Technique
Bjuv uppgraderingsanl.	Bjuv	Skåne	PSA
Bodens uppgraderingsanl.	Boden	Norrbottn	Water wash, re-circulation
Borås uppgraderingsanl.	Borås	Västra Götaland	Chemical absorption
Eskilstuna uppgraderingsanl.	Eskilstuna	Södermanland	Water wash, re-circulation
Eslöv uppgraderingsanl. 1	Eslöv	Skåne	Water wash
Eslöv uppgraderingsanl. 2	Eslöv	Skåne	Water wash
Falköping uppgraderingsanl.	Falköping	Västra Götaland	Water wash, re-circulation
Göteborg uppgraderingsanl.	Göteborg	Västra Götaland	Chemical absorption
Helsingborg uppgraderingsanl. 1	Helsingborg	Skåne	PSA
Helsingborg uppgraderingsanl. 2	Helsingborg	Skåne	Water wash, re-circulation
Jönköping uppgraderingsanl.	Jönköping	Jönköping	Water wash
Kalmar uppgraderingsanl.	Kalmar	Kalmar	Water wash, re-circulation
Kristianstad uppgraderingsanl. 1	Kristianstad	Skåne	Water wash
Kristianstad uppgraderingsanl. 2	Kristianstad	Skåne	Water wash, re-circulation
Laholm uppgraderingsanläggning	Laholm	Halland	Water wash
Lilla Edet uppgraderingsanl	Lilla Edet	Västra Götaland	PSA
Linköping uppgraderingsanl. 1	Linköping	Östergötland	PSA
Linköping uppgraderingsanl. 2	Linköping	Östergötland	Water wash, re-circulation

Linköping uppgraderingsanl. 3	Linköping	Östergötland	Water wash, re-circulation
Norrköping uppgraderingsanl. 1	Norrköping	Östergötland	Water wash
Norrköping uppgraderingsanl. 2	Norrköping	Östergötland	Water wash, re-circulation
Skellefteå uppgraderingsanl.	Skellefteå	Norrbottnen	Water wash
Skövde uppgraderingsanl.	Skövde	Västra Götaland	PSA
Bromma uppgraderingsanl	Stockholm	Stockholm	PSA
Henriksdal uppgraderingsanl 1	Stockholm	Stockholm	Water wash, re-circulation
Henriksdal uppgraderingsanl 2	Stockholm	Stockholm	Water wash, re-circulation
Trollhättan uppgraderingsanl. 1	Trollhättan	Bohuslän	Water wash, re-circulation
Trollhättan uppgraderingsanl. 2	Trollhättan	Bohuslän	Water wash, re-circulation
Ulricehamn uppgraderingsanl.	Ulricehamn	Västra Götaland	PSA
Uppsala uppgraderingsanl. 1	Uppsala	Uppsala	Water wash, re-circulation
Uppsala uppgraderingsanl. 2	Uppsala	Uppsala	Water wash
Västerås uppgraderingsanl.	Västerås	Västmanland	Water wash, re-circulation
Örebro uppgraderingsanl.	Örebro	Örebro	Water wash, re-circulation
Östersund uppgraderingsanl.	Östersund	Jämtland	Water wash, re-circulation

Biogas plants in Sweden

Plant name	Municipality	County	Type of plant
Nolhaga ARV	Alingsås	Västra Götaland	Sewage treatment plant
Alvesta ARV	Alvesta	Kronoberg	Sewage treatment plant
Arboga ARV	Arboga	Västmanland	Sewage treatment plant
Vik ARV	Arvika	Värmland	Sewage treatment plant
Askersund ARV	Askersund	Örebro	Sewage treatment plant
Krylbo ARV	Avesta	Dalarna	Sewage treatment plant
Ekebro ARV	Bjuv	Skåne	Sewage treatment plant
Häggesta ARV	Bollnäs	Gävleborgs	Sewage treatment plant
Borgholms ARV	Borgholm	Kalmar	Sewage treatment plant
Fagersta by ARV	Borlänge	Dalarna	Sewage treatment plant
Gässlösa ARV	Borås	Västra Götaland	Sewage treatment plant
Himmerfjärdsverket	Botkyrka	Stockholm	Sewage treatment plant
Degerfors ARV	Degerfors	Örebro	Sewage treatment plant
Eksjö ARV	Eksjö	Jönköping	Sewage treatment plant
Enköpings ARV	Enköping	Uppsala	Sewage treatment plant
Ekeby ARV	Eskilstuna	Södermanland	Sewage treatment plant
Ellingeverket	Eslöv	Skåne	Sewage treatment plant
Carlberg	Falkenberg	Halland	Sewage treatment plant
Smedjeholms ARV	Falkenberg	Halland	Sewage treatment plant
Hulesjöns ARV	Falköping	Västra Götaland	Sewage treatment plant
Axsätters ARV	Finspång	Östergötland	Sewage treatment plant
Deje ARV	Forshaga	Värmland	Sewage treatment plant

Gislaveds ARV	Gislaved	Jönköping	Sewage treatment plant
Pinjen 1	Gotland	Gotland	Sewage treatment plant
Duvbacken, Gävle vatten ARV	Gävle	Gävleborgs	Sewage treatment plant
Ryaverket	Göteborg	Västra Götalands	Sewage treatment plant
Götene ARV	Götene	Västra Götaland	Sewage treatment plant
Lappkärr ARV	Hagfors	Värmland	Sewage treatment plant
Hallberg ARV	Hallsberg	Örebro	Sewage treatment plant
Mölnatorp ARV	Hallstahammar	Västmanland	Sewage treatment plant
Västra Strandens ARV	Halmstad	Halland	Sewage treatment plant
Fors ARV	Haninge	Stockholm	Sewage treatment plant
Bottenvikens ARV	Haparanda	Norrbottnen	Sewage treatment plant
Brunnas ARV	Hedemora	Dalarna	Sewage treatment plant
Långshyttans ARV	Hedemora	Dalarna	Sewage treatment plant
Öresundsverket	Helsingborg	Skåne	Sewage treatment plant
Reffelmansverket	Hudiksvall	Gävleborgs	Sewage treatment plant
Sösåla ARV	Hässleholm	Skåne	Sewage treatment plant
Hässleholm ARV	Hässleholm	Skåne	Sewage treatment plant
Vinslövs ARV	Hässleholm	Skåne	Sewage treatment plant
Lerums ARV	Höganäs	Skåne	Sewage treatment plant
Höganäs ARV	Höganäs	Skåne	Sewage treatment plant
Ormanäs ARV	Höör	Skåne	Sewage treatment plant
Simsholmens ARV	Jönköping	Jönköping	Sewage treatment plant
Husqvarna ARV	Jönköping	Jönköping	Sewage treatment plant
Kalmar biogasanläggning	Kalmar	Kalmar	Sewage treatment plant
Sternö ARV	Karlshamn	Blekinge	Sewage treatment plant
Mörrums ARV	Karlshamn	Blekinge	Sewage treatment plant
Aggeruds ARV	Karlskoga	Örebro	Sewage treatment plant
Sjöstads ARV	Karlstad	Värmland	Sewage treatment plant
Rosenholms RV	Katrineholm	Södermanland	Sewage treatment plant
Klippans ARV	Klippan	Skåne	Sewage treatment plant
Centrala ARV	Kristianstad	Skåne	Sewage treatment plant
Fiskartorpet ARV	Kristinehamn	Värmland	Sewage treatment plant
Kumla ARV	Kumla	Örebro	Sewage treatment plant
Kävlinge ARV	Kävlinge	Skåne	Sewage treatment plant
Hedhuset ARV	Laholm	Halland	Sewage treatment plant
Ängstorps ARV	Laholm	Halland	Sewage treatment plant
Lundåkraverket	Landskrona	Skåne	Sewage treatment plant
Lerums reningsverk	Lerum	Västra Götaland	Sewage treatment plant
Käppalaverket	Lidingö	Stockholm	Sewage treatment plant
Nykvarn ARV	Linköping	Östergötland	Sewage treatment plant
Ljungby ARV	Ljungby	Kronoberg	Sewage treatment plant
Bångbro ARV	Ljusnarsberg	Örebro	Sewage treatment plant

Gårlångens ARV	Ludvika	Dalarna	Sewage treatment plant
Gonäs ARV	Ludvika	Dalarna	Sewage treatment plant
Uddeboverket	Luleå	Norrbottnen	Sewage treatment plant
Södra Sandby ARV	Lund	Skåne	Sewage treatment plant
Veberöds ARV	Lund	Skåne	Sewage treatment plant
Källby ARV	Lund	Skåne	Sewage treatment plant
Långeviksverket 1	Lysekil	Västra Götaland	Sewage treatment plant
Långeviksverket 2	Lysekil	Västra Götaland	Sewage treatment plant
Klagshamns ARV	Malmö	Skåne	Sewage treatment plant
Sjölunda ARV	Malmö	Skåne	Sewage treatment plant
Mariestads ARV	Mariestad	Västra Götaland	Sewage treatment plant
Sunnanå ARV	Mellerud	Skåne	Sewage treatment plant
Karshults ARV	Motala	Östergötland	Sewage treatment plant
Gäddenäs ARV	Mönsterås	Kalmar	Sewage treatment plant
Nora ARV	Nora	Örebro	Sewage treatment plant
Persbo ARV	Norberg	Västmanland	Sewage treatment plant
Slottshagens ARV	Norrköping	Östergötland	Sewage treatment plant
Lindholmens ARV	Norrtälje	Stockholm	Sewage treatment plant
Rimbo ARV	Norrtälje	Stockholm	Sewage treatment plant
Brandholmens ARV	Nyköping	Östergötland	Sewage treatment plant
Nynäshamns ARV	Nynäshamn	Stockholm	Sewage treatment plant
Ernemars ARV	Oskarshamn	Kalmar	Sewage treatment plant
Perstorp ARV	Perstorp	Skåne	Sewage treatment plant
Sandholmens ARV	Piteå	Norrbottnen	Sewage treatment plant
Lerdals ARV	Rättvik	Dalarna	Sewage treatment plant
Sala ARV	Sala	Västmanland	Sewage treatment plant
Hedåsens ARV	Sandviken	Gävleborgs	Sewage treatment plant
Sjöbo ARV	Sjöbo	Skåne	Sewage treatment plant
Skara ARV	Skara	Västra Götaland	Sewage treatment plant
Skellefteå ARV	Skellefteå	Västerbotten	Sewage treatment plant
Stadskvarn ARV	Skövde	Västra Götaland	Sewage treatment plant
Bylandets ARV	Smedjebacken	Dalarna	Sewage treatment plant
Hågesta ARV	Sollefteå	Västernorrland	Sewage treatment plant
Omholmens ARV	Sotenäs	Västra Götaland	Sewage treatment plant
Henriksdal ARV	Stockholm	Stockholm	Sewage treatment plant
Bromma ARV	Stockholm	Stockholm	Sewage treatment plant
Essviksverket	Sundsvall	Västernorrland	Sewage treatment plant
Tivoliverket	Sundsvall	Västernorrland	Sewage treatment plant
Fillanverket	Sundsvall	Västernorrland	Sewage treatment plant
Haga ARV	Surahammar	Västmanland	Sewage treatment plant
Tibro ARV	Tibro	Västra Götaland	Sewage treatment plant
Rosendals ARV	Tomelilla	Skåne	Sewage treatment plant

Tranås ARV	Tranås	Jönköping	Sewage treatment plant
Trelleborgs ARV	Trelleborg	Skåne	Sewage treatment plant
Anvidstorps ARV	Trollhättan	Västra Götaland	Sewage treatment plant
Skansverket	Uddevalla	Västra Götaland	Sewage treatment plant
Ulricehamns ARV	Ulricehamn	Västra Götaland	Sewage treatment plant
Öns ARV	Umeå	Västerbotten	Sewage treatment plant
Storvreta ARV	Uppsala	Uppsala	Sewage treatment plant
Kungsängsverket	Uppsala	Uppsala	Sewage treatment plant
Vadstena ARV	Vadstena	Östergötland	Sewage treatment plant
Varbergs ARV	Varberg	Halland	Sewage treatment plant
Vimmerby ARV	Vimmerby	Kalmar	Sewage treatment plant
Vingåkers ARV	Vingåker	Södermanland	Sewage treatment plant
Holmängens ARV	Vänersborg	Västra Götaland	Sewage treatment plant
Tjustvik ARV	Värmdö	Stockholm	Sewage treatment plant
Värnamo ARV	Värnamo	Jönköping	Sewage treatment plant
Västerviks ARV	Västervik	Kalmar	Sewage treatment plant
Kungsängen ARV	Västerås	Västmanland	Sewage treatment plant
Sundet ARV	Växjö	Kronoberg	Sewage treatment plant
Ystad ARV	Ystad	Skåne	Sewage treatment plant
Nyvångsverket	Åstorp	Skåne	Sewage treatment plant
Häckla ARV	Åtvidaberg	Östergötland	Sewage treatment plant
Älmhults ARV	Älmhult	Kronoberg	Sewage treatment plant
Ängelholms ARV	Ängelholm	Skåne	Sewage treatment plant
Skebäck ARV	Örebro	Örebro	Sewage treatment plant
Örkelljunga ARV	Örkelljunga	Skåne	Sewage treatment plant
Knorthem ARV	Örnsköldsvik	Västernorrland	Sewage treatment plant
Bodum ARV	Örnsköldsvik	Västernorrland	Sewage treatment plant
Prästbordet ARV	Örnsköldsvik	Västernorrland	Sewage treatment plant
Gövikens ARV	Östersund	Jämtland	Sewage treatment plant
Östhammar ARV	Östhammar	Uppsala	Sewage treatment plant
Östra Göinge ARV	Östra Göinge	Skåne	Sewage treatment plant
Bältinge avfallsanläggning	Alingsås	Västra Götaland	Landfill
Mossebergs avfallsanläggning	Arvika	Värmland	Landfill
Brändkläppens avfallsanläggning	Boden	Norrbottn	Landfill
Fågelmåra avfallsanläggning	Borlänge	Dalarna	Landfill
Åsens avfallsanläggning	Bromölla	Skåne	Landfill
Annelund avfallsstation	Enköping	Uppsala	Landfill
Lilla Nyby avfallsanläggning	Eskilstuna	Södermanland	Landfill
Rönneholms avfallsanläggning	Eslöv	Skåne	Landfill
Falköpings avfallsanläggning	Falköping	Västra Götaland	Landfill
Falu avfallsanläggning	Falun	Dalarna	Landfill
Slite avfallsanläggning	Gotland	Gotland	Landfill

Forsbacka avfallsanläggning	Gävle	Gävleborg	Landfill
Tagene avfallsanläggning	Göteborg	Västra Götaland	Landfill
Holkesmossen	Hagfors	Värmland	Landfill
Filborna	Helsingborg	Skåne	Landfill
Sofielunds återvinningsanläggning	Huddinge	Stockholm	Landfill
Ulvbergets avfallsanläggning	Hudiksvall	Gävleborg	Landfill
Älands avfallsanläggning	Härnösand	Västernorrland	Landfill
Vankiva avfallsanläggning	Hässleholm	Skåne	Landfill
Hults avfallsanläggning	Jönköping	Jönköping	Landfill
Kalix avfallsdeponi	Kalix	Norrbottn	Landfill
Moskogen	Kalmar	Kalmar	Landfill
Avfallsverket i Mörrum	Karlshamn	Skåne	Landfill
Bubbetorps avfallsanläggning	Karlskrona	Blekinge	Landfill
Lersätters avfallshanteringområde	Kil	Värmland	Landfill
Hyllstofta	Klippan	Skåne	Landfill
Landskrona- Svalöv	Landskrona	Skåne	Landfill
Bredemads avfallsupplag	Ljungby	Kronoberg	Landfill
Björnhyttans avfallsanläggning	Ludvika	Dalarna	Landfill
Sunderby avfallsanläggning	Luleå	Norrbottn	Landfill
Spillepengs avfallsanläggning	Malmö	Skåne	Landfill
Koviks avfallsanläggning	Nacka/Värmdö	Stockholm	Landfill
Häradsudden	Norrköping	Södermanland	Landfill
Björshults avfallsanläggning	Nyköping	Södermanland	Landfill
Boda avfallsanläggning	Nässjö	Jönköping	Landfill
Storskogen	Oskarshamn	Kalmar	Landfill
Bredviksbergets avfallsanläggning	Piteå	Norrbottn	Landfill
Isåtra avfallsstation	Sala	Västmanland	Landfill
Måsalycke avfallsanläggning	Simrishamn	Skåne	Landfill
Rödjornas återvinningsanläggning	Skara	Västra Götaland	Landfill
Risängen	Skövde	Västra Götaland	Landfill
Blåbergets avfallsanläggning	Sundsvall	Västernorrland	Landfill
Holmby avfallsupplag	Sunne	Värmland	Landfill
Tveta återvinningsanläggning	Södertälje	Stockholm	Landfill
Norraby deponi	Tranås	Jönköping	Landfill
Trelleborgs avfallsanläggning	Trelleborg	Skåne	Landfill
Avfallsupplaget vid Karthemmet	Ulricehamn	Västra Götaland	Landfill
Dåva deponi och avfallsanläggning	Umeå	Västerbotten	Landfill
Högbytorp	Upplands-Bro	Stockholm	Landfill
Löt Avfallsanläggning	Vallentuna	Stockholm	Landfill
Flishults avfallsanläggning	Vetlanda	Jönköping	Landfill
TRAB avfallsanläggning	Vänersborg	Västra Götaland	Landfill
Stomsjö	Värnamo	Kronoberg	Landfill

Gryta avfallsstation	Västerås	Västmanland	Landfill
Häringetorps avfallsanläggning	Växjö	Kronoberg	Landfill
Hedeskoga avfallsanläggning	Ystad	Skåne	Landfill
Östby miljöstation	Åmål	Västra Götaland	Landfill
Atleverkets avfallsanläggning	Örebro	Örebro	Landfill
Må avfallsanläggning	Örnsköldsvik	Västernorrland	Landfill
Gräfsåsens avfallsanläggning	Östersund	Jämtland	Landfill
Örtofta sockerbruk	Eslöv	Skåne	Industrial
Biotrans	Umeå	Västerbotten	Industrial
Domsjö Fabriken AB	Örnsköldsvik	Västernorrland	Industrial
Wrangs-Gunnarstorp	Bjuv	Skåne	Farm-based
Lövsta biogasanläggning	Gotland	Gotland	Farm-based
Svenstorps biogasanläggning	Götene	Västra Götaland	Farm-based
Plönninge biogasanläggning	Halmstad	Halland	Farm-based
Hällingsbo biogasanläggning	Lerum	Västra Götaland	Farm-based
Alviksgården	Luleå	Norrbottnen	Farm-based
Hagavik biogasanläggning	Malmö	Skåne	Farm-based
Nynäs Gårds biogasanläggning	Nyköping	Södermanland	Farm-based
Svedjans biogasanläggning	Boden	Norrbottnen	Co-digestion
Sobackens avfallsanläggning	Borås	Västra Götaland	Co-digestion
Falköpings samrötningsanläggning	Falköping	Västra Götaland	Co-digestion
Filborna	Helsingborg	Skåne	Co-digestion
SRV Återvinning AB	Huddinge	Stockholm	Co-digestion
Jönköping	Jönköping	Jönköping	Co-digestion
Kalmar biogasanläggning	Kalmar	Kalmar	Co-digestion
Kils biogasanläggning	Kil	Värmland	Co-digestion
Karpalund	Kristianstad	Skåne	Co-digestion
Laholms biogasanläggning	Laholm	Halland	Co-digestion
Linköping	Linköping	Östergötland	Co-digestion
Skellefteå	Skellefteå	Västerbotten	Co-digestion
Skövde biogasanläggning	Skövde	Västra Götaland	Co-digestion
Uppsala	Uppsala	Uppsala	Co-digestion
Vetlanda	Vetlanda	Jönköping	Co-digestion
TRAAB samrötningsanläggning	Vänersborg	Västra Götaland	Co-digestion
Svensk Växtkraft	Västerås	Västmanland	Co-digestion
Älmhult	Älmhult	Kronoberg	Co-digestion

References and suggested reading

Namn/Utgivare (årtal)	Titel	Länk
Benjaminsson Johan (2006)	SGC Rapport 163 Nya renings- och uppgraderingstekniker för biogas	www.sgc.se
Benjaminsson Johan and Linné Marita (2007)	SGC Rapport 178 Biogasanläggningar med 300 GWh årsproduktion - system, teknik och ekonomi	www.sgc.se
Berg Jessica (2000)	Lagring och hantering av rötresten från storskaliga biogasanläggningar	www.jti.se JTI rapport 22, Kretslopp och avfall
Berglund Maria (2006)	Biogas production from a systems analytical perspective	www.miljo.lth.se
Berglund Maria and Börjesson Pål (2003)	Energianalys av biogassystem, (Energy systems analysis of biogas systems)	www.miljo.lth.se
Börjesson Pål (2004)	Energianalys av drivmedel från spannmål och vall	www.miljo.lth.se
Clementson Margareta (2007)	SGC Rapport Basic data on biogas – Sweden	www.sgc.se
Dahl Anders (2005)	SGC Rapport Inventering och utvärdering av analysinstrument och flödesmätare för gasmätning i uppgraderingsanläggningar för biogas	www.sgc.se
E.ON Gas Sverige AB, LRF, LRF konsult, Svenska Gasföreningen and Svenska Biogasföreningen (2007)	Gårdsproduktion av biometan	www.gasforeningen.se
Edström Mats and Nordberg Åke (2004)	Producera biogas på gården-gödsel, avfall och energigrödor blir värme och el	www.gasforeningen.se
Edström Mats, Nordberg Åke and Ringmar Anders (2005)	Utvärdering av gårdsbaserad biogasanläggning på Hagavik.	www.jti.se JTI rapport 31. Kretslopp och avfall
GASTEC, Danish Gas Technology Center and Svenskt Gastekniskt center (2001)	SGC Rapport 118 Adding gas from biomass to the gas grid	www.sgc.se
Gustavsson Mathias, Ellegård Anders (2004)	Stommens biogasanläggning.	www.jti.se JTI rapport 30, Kretslopp och avfall
Håkansson Anna (2006)	SGC Rapport 166 Preventing microbial growth on pall-rings when upgrading biogas using absorption with water wash	www.sgc.se
Held Jörgen (2007)	SGC rapport Energigasernas roll för ett hållbart energisystem, del 2	www.sgc.se
Hidén Sofia (2003)	Modellering och styrning av en biogasprocess: tillämpning av ADM1-	www.jti.se JTI rapport 28, Kretslopp och

	modellen.	avfall
IEA Bioenergy- Task 37	Biogas upgrading and utilization	www.iea-biogas.net
Johansson Mårten and Nilsson Thomas (2007)	Transporter i gårdsbaserade biogassystem - Framtagning av beräkningsprogram för kostnader och emissioner, (Transport in farm-based biogas systems - Development of a calculation program for costs and emissions)	www.miljo.lth.se
Jönsson Owe (2006)	SGC Rapport 170 Utveckling och demonstration av användning av metan/vätgasblandningar som bränsle i befintliga metangasdrivna bussar.	www.sgc.se
Lantz Mikael (2004)	Gårdsbaserad produktion av biogas för kraftvärme - ekonomi och teknik, (Farm based biogas production for combined heat and power - economy and technology)	www.miljo.lth.se
Linné Maritta and Jönsson Owe (2004)	Sammanställning och analys av potentialen för produktion av förnyelsebar metan (biogas och SNG) i Sverige	www.gasforeningen.se
Mårtensson Ellen (2007)	Biogas as a vehicle fuel in the Stockholm region – scenario 2020	Examensarbete KTH
Nationellt samverkansprojekt biogas i fordon Mats Edström, Nils Hanners, Åke Nordberg (2004)	Förstudie om biogas för fordon på Arlanda flygplats och i Sigtuna kommun	www.sbgf.info
Nationellt samverkansprojekt biogas i fordon Lars Brolin, Jean B Collin, Hans Nilsson, Rose-Marie Ågren, Katja Uusitalo(2005)	Förstudie om produktionsförutsättningar samt marknadsanalyser för CBG efter Norra Norrlandskusten	www.sbgf.info
Nationellt samverkansprojekt biogas i fordon Åke Nordberg, Mats Edström, Marketta Uusi-Penttilä and Åke Rasmuson (2004)	Utveckling av processintern metananrikning	www.sbgf.info
Nationellt samverkansprojekt biogas i fordon (2004)	Utveckling av jordbrukets roll inom biogasområdet	www.sbgf.info
Nationellt samverkansprojekt biogas i fordon (2004)	Ökad biogasproduktion i Göteborgsregionen	www.sbgf.info
Nationellt samverkansprojekt biogas i fordon (2004)	Utveckling av biogas för fordon Skaraborg/Skövde	www.sbgf.info

Nationellt samverkansprojekt biogas i fordon (2005)	Konvertering av lastbil till biogasdrift med dual-fuel teknik	www.sbgf.info
Nationellt samverkansprojekt biogas i fordon (2005)	Effektivitet av fordonsdesinfektion för transport av rötrest	www.sbgf.info
Nationellt samverkansprojekt biogas i fordon (2005)	Utveckling av infrastruktur och marknad för biogas för fordon i Sjuhäradsområdet	www.sbgf.info
Nationellt samverkansprojekt biogas i fordon Darijo Ondelj and Farhad Hadi (2005)	Utvecklingsbehov inom dual-fuel för tunga fordon	www.sbgf.info
Nationellt samverkansprojekt biogas i fordon Johan E Carlsson and Jerker Delsing (2004)	Mätning av energi och sammansättning av gasblandningar med ultraljud	www.sbgf.info
The Swedish Environmental Protection Agency. Naturvårdsverket (2005)	Biogas plants with potential – Evaluation of LIP-financed systems for anaerobic digestion and composting.	www.naturvardsverket.se
Nilsson Sören (2000)	Gårdsbaserad biogas på Plönninge naturbruksgymnasium	www.jti.se JTI rapport 21, Kretslopp och avfall
Nordberg Ulf (2006)	Biogas - Nuläge och framtida potential	www.varmeforsk.se
Norin Erik (2007)	SGC Rapport 179 Alternativa hygieniseringsmetoder	www.sgc.se
Persson Margareta (2006)	SGC Rapport Biogasfolder 2006	www.sgc.se
Persson Margareta (2003)	SGC Rapport 142 Utvärdering av uppgraderingstekniker för biogas	www.sgc.se
Persson Margareta, Jönsson Owe, Ekstrandh Alexandra and Dahl Anders (2007)	SGC Rapport 172 Frivilligt åtagande - inventering av utsläpp från biogas- och uppgraderingsanläggningar	www.sgc.se
Pettersson Anna, Losciale Michael and Liljemark Stefan (2007)	SGC Rapport 177 LCMG - pilotprojekt för LMG som fordonsbränsle i Sverige	www.sgc.se
Swedish Biogas Association (2004)	Biogas, renewable energy from organic waste.	www.sbgf.info
Svenska Biogasföreningen (2006)	SGC Rapport Energigas och miljömål	www.sgc.se
Svenska Gasföreningen (2005)	Biogasanvisningarna (BGA)	www.gasforeningen.se
Svenska Gasföreningen (2006)	Tankstationsanvisningar (TSA)	www.gasforeningen.se
Vågström Lena (2005)	Evaluation of a handling system for ley crop used in biogas production.	www.jti.se JTI rapport 32, Kretslopp och avfall
Vinnerås Björn (2005)	SGC Rapport Mikrobiell analys av biogas	www.sgc.se

This handbook describes the biogas process, from the use of substrates to the final distribution of biogas and organic residues. General information is given on biogas technologies, the benefits to the environment and to society. Twelve Swedish biogas plants are then described, which have been particularly successful, and which can therefore serve as models for the future. Most of these have received financial support via LIP and KLIMP. This support has been vital for the development of many of these biogas plants.

This handbook is published by the Swedish Gas Centre, the Swedish Gas Association and the Swedish Biogas Association and these associations take full responsibility for the contents. The Swedish Environmental Protection Agency and Swentec (Swedish Environmental Technology Council) provided financial support for the production and translation of this handbook.

Financial support from:



SWEDISH ENVIRONMENTAL
PROTECTION AGENCY



SWENTEC
*Swedish Environmental
Technology Council*